

1 Aero Gas Turbines

Tim Snyder, Dusty Davis, and Randy McKinney

1.1 Introduction

Gas turbine engines for aircraft applications are complex machines requiring advanced technology drawing from the disciplines of fluid mechanics, heat transfer, combustion, materials science, mechanical design, and manufacturing engineering. In the very early days of gas turbines, the combustor module was frequently the most challenging (Golley et al., 1987). Although the capability of the industry to design combustors has greatly improved, challenges still remain in the design of the combustor, and further innovations are required to reduce carbon emissions. Many companies in the aviation industry committed to a pathway to carbon-neutral growth and aspired to a carbon-free future in 2008 (Air Transportation Action Group, 2008). Additionally, airframers have aggressive goals to reduce carbon dioxide emissions by 50% by 2050 compared to those in 2005 (Airbus, 2021). Achieving these goals require technology advancements in all aspects of the aviation industry, including airframers, engine manufacturers, fuel providers, and all the associated supply chains. The focus of this chapter is the influence of one module of the aircraft engine – the combustor. The approach to meeting these goals must come with the combination of higher fuel-efficiency engines and the use of alternative jet fuels starting with sustainable aviation fuels (SAFs) followed by the introduction of renewable carbon-free fuels that may include hydrogen and ammonia. The transition to alternative fuels has already begun by blending 10%–50% of SAFs with jet fuel, with the additional benefit of lower carbon particulates in the exhaust. It is anticipated that gas turbine combustors will be capable of operating on 100% SAFs within the next few years, followed by demonstrators that burn carbon-free fuels.

This chapter will describe how the combustor interacts with the rest of the engine and flight vehicle, by describing the relationship between attributes of the engine and the resulting requirements for the combustor. Emissions, a major engine performance characteristic that relies heavily on combustor design, will be introduced here with more detail to be found in following chapters. Another major challenge for the aircraft combustor design is the wide range of operating conditions that a combustor must meet as engine thrust varies. The combustor operability can be affected by alternative fuels. In most cases, changes to the combustor design or fuel

distribution to improve combustor operability can also affect combustion dynamics, emissions, combustor durability, and the combustor exit temperature distribution, which impacts turbine section durability. Changes to the overall propulsion efficiency can be made by increasing the bypass ratio and the overall engine pressure ratio, which can further increase the combustor range of operating conditions. To meet these challenges, significant investments are expected to better understand how the combustor can meet the overall engine requirements for a variety of fuel types.

1.2 Overview of Selected Aircraft and Engine Requirements and Their Relation to Combustor Requirements

Gas turbine engines have been used in many different sizes of aircraft since their introduction in the 1940s. Small aircraft such as single-engine turboprops use engines of low shaft horsepower, which are of small physical size. Business jets and smaller passenger aircraft may use turbojets or turbofans with thrust in the range of several thousand pounds, usually with two engines per aircraft. The other extreme includes four-engine aircraft with turbofan engine thrusts as high as 70,000 pounds and very large twin-engine aircraft with thrust per engine in the 100,000-pound class. These large thrust designs are also physically very large with fan diameters over 100 inches. In all of these applications, the engine system imposes a common set of requirements upon the combustor, as summarized in Table 1.1.

As shown in Figure 1.1, these requirements are interdependent. Years of design and development within the industry have produced successive designs that improve upon all of the requirements concurrently. Although emissions are a key combustor constraint, each of these other requirements interacts with emissions and will be introduced briefly.

Table 1.1 Engine system-level requirements and supporting combustor characteristics

Engine requirements	Combustor characteristics
Optimize fuel consumption	High combustion efficiency and low combustor pressure loss
Meet emission requirements	Minimize emissions and smoke
Wide range of thrust	Good combustion stability over entire operating range
Ground and altitude starting	Easy to ignite and propagate flame
Turbine durability	Good combustor exit temperature distribution
Overhaul and repair cost	Meet required combustor life by managing metal temperatures and stresses

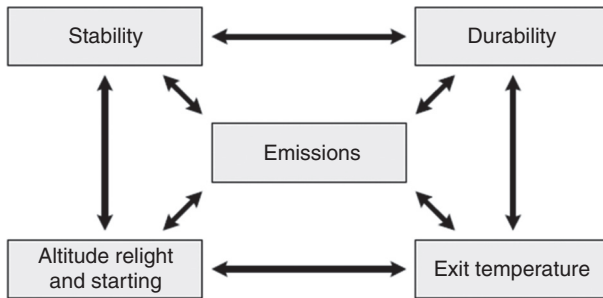

Figure 1.1 Combustor performance requirements are interrelated.

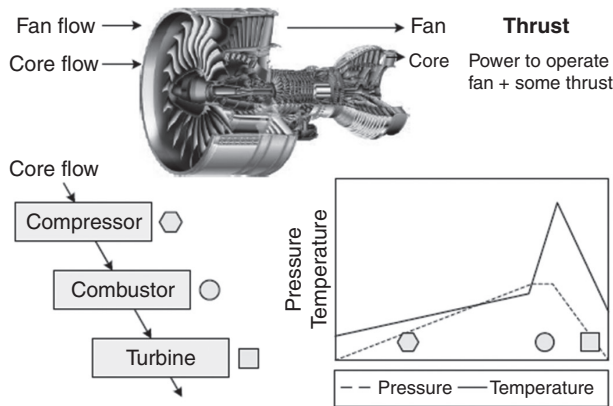

Figure 1.2 Summary of component characteristics.

1.3 Combustor Effects on Engine Fuel Consumption

Gas turbine engines are Brayton cycle devices. An ideal version of such a cycle comprises isentropic compression, addition of heat at constant pressure, and isentropic expansion through the turbine. Figure 1.2 is a simplified schematic of the effect of such a cycle on the pressures and temperatures in the engine. In real engines, all of the processes incur some loss of performance versus the ideal, which is manifested as a stagnation pressure loss in the combustor. Combustion systems incur pressure losses because of flow diffusion and turning, jet mixing, and Rayleigh losses during heat addition (Lefebvre and Ballal, 2010). However, at most power conditions, the efficiency with which the fuel chemical energy is converted into thermal energy is very high, typically greater than 99.9%. “Low” levels of 98%–99.5% can be seen at low power levels. In general, though, the combustion system is a small parasitic effect on overall fuel consumption.

1.4 Fundamentals of Emissions Formation

The pollutants emitted by engines that are of most interest include carbon monoxide (CO), unburned hydrocarbons (UHC), nitric oxides (NO_x), and particulate matter (PM) or smoke. At low power conditions, the inlet combustor pressure and temperature are relatively low, and reaction rates for kerosene type fuels are low. Liquid fuel must be atomized, evaporated, and combusted, with sufficient residence time at high enough temperatures to convert the fuel into CO₂. If the flow field permits fuel vapor to exit the combustor without any reaction or if partially reacted to species of lower molecular weights, there will be UHC present. If a portion of the flow field subjects a reacting mixture to a premature decrease in temperature via mixing with cold air streams, these incomplete or quenched reactions lead to the production of CO, as detailed in Chapter 13.

At high power conditions, high pressures and temperatures lead to fast reactions, with the result that CO and UHC are nearly zero. At these elevated temperatures, emissions of NO_x and PM become more prevalent. NO_x can be formed through several processes, but the dominant pathway is thermal NO_x, as described by the extended Zeldovich mechanism, as also detailed in Chapter 13.

The formation rate is exponentially related to the temperature in the flame peaking near stoichiometric conditions. Thermal NO_x emissions can be reduced by limiting the time the flow spends at the high temperature and/or by reducing the maximum temperatures seen in the flame via stoichiometry control. Other NO_x formation mechanisms, such as NO_x formed in the flame zone itself, are negligible for aircraft engines.

When fuel-rich regions of the combustor flow exist at high pressures and temperatures, the formation of small particles of carbon can occur. These carbon particles result from complex chemical reactions and undergo multiple processes within the combustor like surface growth, agglomeration, and oxidation prior to leaving the combustor, as detailed in Chapter 13. The particles formed in the combustor pass through the turbine and exit the engine in the exhaust. When the concentration of the particles in the exhaust is high enough to be visible, as was often the case in early gas turbines, it is referred to as smoke or soot. Recently, the more general term of PM has been used to describe this emission. Modern engine smoke levels are invisible but still possess a large number of very small soot particles and aerosol soot precursors at the exhaust. Emerging research on the effect of PM on health and climate is focusing more attention on measuring, modeling, and understanding the processes governing PM production.

These relationships between engine power conditions and emission production lead to the behavior shown in Figure 1.3. As shown in the figure, levels of UHC and CO are highest at low power and drop quickly with increasing thrust. Conversely, NO_x and PM increase with engine power and are typically maximized at maximum power.

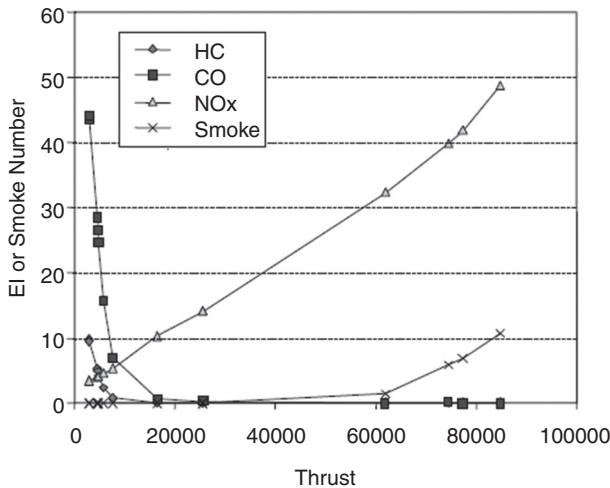

Figure 1.3 Emissions versus power level for the PW4084.

1.5 Effect of Range of Thrust and Starting Conditions on the Combustor

Flight gas turbine engines must provide a range of thrust and thrust response in order to power the aircraft mission. Missions vary depending on the aircraft application. Commercial aircraft and military transports have similar missions. Military fighters and other specialized aircraft can have very different missions since their use is not exclusively for the transport of payload between two points. Design requirements are also very different for commercial and military applications. Military fighter engines are often designed for maximized thrust developed per unit weight so that the maneuverability of the aircraft is maximized. Military fighter engines also fly at a wide range of thrust throughout the flight envelope and must undergo frequent rapid thrust transients. Typically, commercial engines are designed for maximum fuel efficiency per unit thrust. They fly at high altitude to achieve the best fuel efficiency and often do not have to endure the aggressive and numerous thrust transients of military fighter engines. Engine combustors must be able to operate stably and efficiently over the full range of operating conditions and must reliably relight if an engine shutdown or flameout should occur in flight.

1.5.1 Engine Mission Characteristics

A typical commercial engine mission consists of ground starting, taxi, take-off, climb to altitude, cruise, deceleration to flight idle and descent, approach, touchdown, thrust reverse, and taxi in. The extremes in combustor-operating conditions drive the overall design approach. The combustor must meet performance, operability, and emissions metrics over the full range of operation. In order to do so, it must operate at the following extremes:

1. **Minimum fuel–air ratio:** This occurs during decelerations from high power to low power. Flight decelerations normally occur when descending from high-altitude cruise and during approach throttle movements. They can also occur in emergencies. Minimum fuel–air ratio typically depends on the thrust decay rate, as the time response of the engine turbomachinery that governs the airflow is much longer than that of the fuel flow. Risk of weak extinction (flameout) is highest during decelerations.
2. **Minimum operating temperatures and pressures:** These occur at flight and ground idle conditions. Low pressure and temperature challenges combustion efficiency due to slower fuel vaporization and chemical kinetics.
3. **High operating temperatures and pressures:** These occur at take-off, climb, thrust reverse, and cruise conditions. These conditions result in the bulk of NO_x formation and the most severe liner metal temperatures.
4. **Ignition conditions:** Ignition normally occurs on the ground but also occasionally in flight. Ignition is required at near surrounding ambient pressure and temperature. High altitude and extremely cold conditions are typically the most challenging to achieve ignition, flame propagation, and flame stabilization. These conditions lead to low temperature (−40°F) and pressure (4 psia at 35,000 ft.) combustor inlet conditions.

Thus, the combustor design must meet the performance, emissions, and durability requirements at low- and high-power operations without compromising stability and ignition. This requires favorable combustion fuel–air stoichiometry to meet requirements at all operating conditions. Two principal approaches have been used to achieve stoichiometry control in the industry. The first, fixed geometry without fuel staging, is the most common approach and is in the large majority of engines in service. These systems have all fuel injectors operating at all conditions. The second approach controls local fuel–air ratio through fuel staging. In these systems, not all fuel injectors operate at low power. This enables more active control of the local combustion fuel–air ratio.

1.5.2 Fixed-Geometry Rich-Quench-Lean (RQL) Combustors

Fixed-geometry combustors have been used in the gas turbine industry since its inception. Early designs used multiple cans in a circumferential array. The cans transitioned through an annular duct to the turbine (Figure 1.4(a)). Later designs used an annular duct geometry that allowed for reduced overall length and weight (Figure 1.4(b)). Annular combustors also have a reduced liner surface area relative to can-annular combustors and therefore use less cooling.

All designs use multiple fuel injectors to provide spray atomization and fuel–air mixing. Achieving good atomization and fuel–air mixing is critical for efficient combustion, low emissions, and good temperature uniformity into the turbine. Normally, the fuel is injected in the front end of the combustor, and flow recirculation is created to provide a stabilization region for the combustion process. This is typically

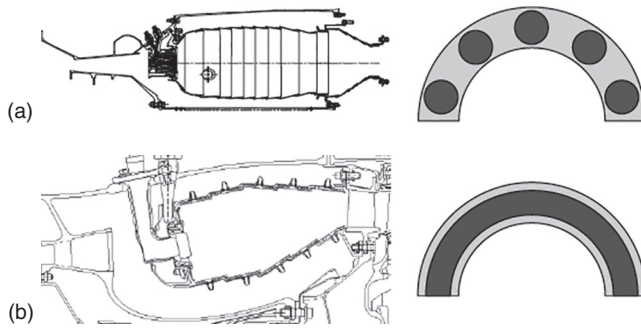

Figure 1.4 (a) Can-annular combustor (Pratt & Whitney JT8D-200). (b) RQL annular combustor (IAE V2500).

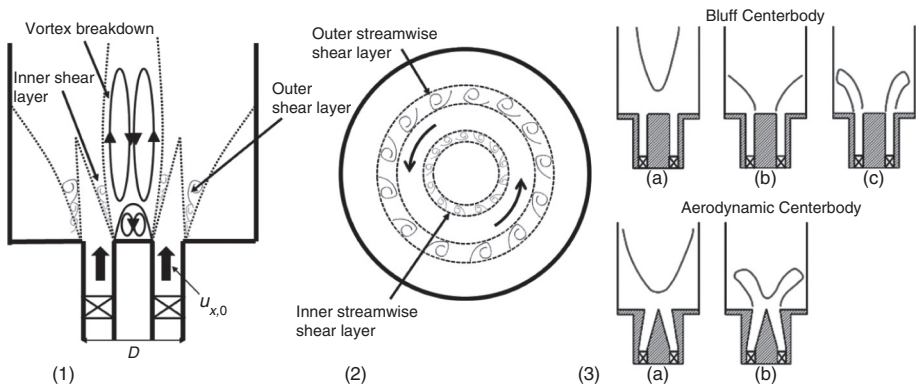

Figure 1.5 Possible flow (1 and 2) and flame (3) configurations for two different vortex breakdown bubble structures where (a) the bubble is lifted and (b, c) the bubble is merged with the centerbody wake. Left two images: courtesy of J. O'Connor. Right images are reproduced from Tim Lieuwen, *Unsteady Combustor Physics*, 2nd edition, January 2022, Cambridge University Press.

accomplished with air swirlers, which leads to vortex breakdown and flow recirculation (see Figure 1.5).

The stabilization zone promotes recirculation of hot product gases forward to the incoming fuel spray, thereby providing a continuous ignition source and faster fuel droplet evaporation. Accelerated droplet evaporation is critical to high-efficiency combustion at low-power conditions, when low air inlet temperatures are insufficient to provide fast enough evaporation. If continuous ignition is not provided at low power, the vaporization and reaction times can exceed the combustor residence time and flameout occurs.

The airflow distribution in a fixed-geometry combustor must be selected to achieve both low- and high-power performance requirements. Conditions at the combustor inlet vary significantly between low-power idle and high-power take-off conditions. At idle, inlet temperature, pressure, and global fuel-air ratio are relatively low. At take-off, the opposite is true (Figure 1.6). The operating temperatures

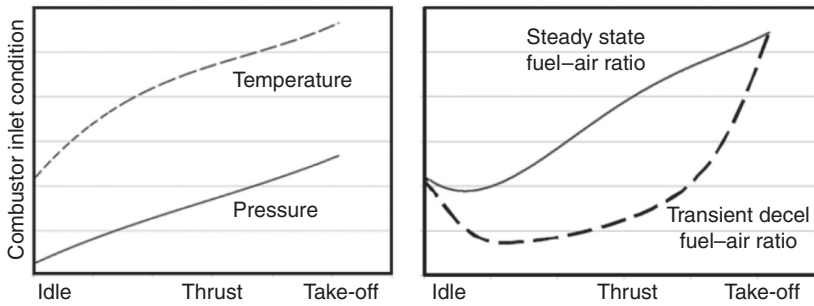

Figure 1.6 Combustor operating conditions.

and pressures are largely a function of the engine thermodynamic cycle; therefore, the most significant parameter for the combustor designer to consider is the fuel–air ratio. Since air is introduced in stages along the length, the designer can tailor the airflow distribution to achieve key performance metrics. This creates a distribution in the fuel–air ratio along the length of the combustor, leading to variations in local temperature as the power level is adjusted. The difference in the fuel–air ratio between high-power take-off and low-power deceleration and idle conditions is critical since it determines the range of the local fuel–air ratio in the front end of the combustor. For most modern gas turbines, the difference is large enough that the front end is fuel rich (fuel to air ratio (f/a) of > 0.068 for jet fuel) at take-off conditions. Consequently, fixed-geometry combustors are referred to as rich burning or RQL designs. This refers to the rich front-end fuel–air ratio that is diluted (quenched) by additional airflow in the downstream section of the combustor to reach the fuel-lean conditions at the combustor exit. The RQL-type design has several advantages and challenges that are discussed in what follows.

As previously described, the challenges at low power are combustion efficiency and stability. The local fuel–air ratio in the RQL combustor front end at idle is designed to generate high recirculating gas temperatures (Figure 1.7). Therefore, the local fuel–air ratio should be near the stoichiometric ($f/a \sim 0.068$ for jet fuel) fuel–air ratio to achieve high combustion efficiency. High combustion efficiency minimizes UHC and CO emissions that predominate at idle. Some increase in NO_x emissions is generated by the hot front end, but emissions at idle are not significant when compared to high power. By designing for near-stoichiometric conditions at idle, stability can be ensured at deceleration conditions, where minimum fuel–air ratio occurs. If the minimum fuel–air ratio during deceleration is not more than 1/3 below idle fuel–air ratio, the local fuel–air ratio in the front end is maintained above the weak extinction limit and flameout is avoided. Limiting of minimum deceleration fuel–air ratio is accomplished by the engine control and controls the maximum thrust decay rate for the engine transient.

At high-power conditions, the principal emission challenges are NO_x and smoke. The RQL combustor axial temperature distribution at high power is depicted in

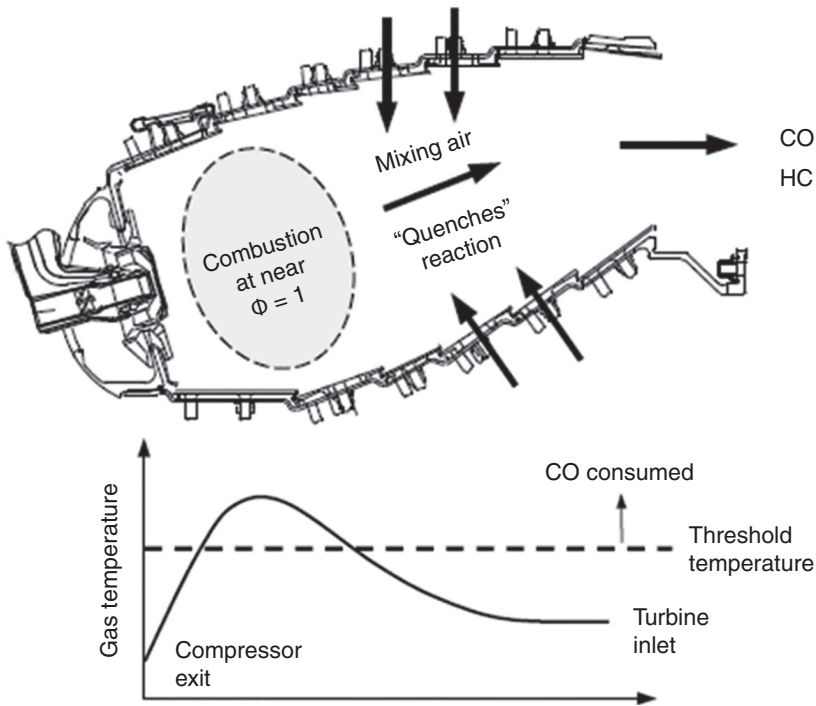

Figure 1.7 Combustor at low power.

Figure 1.8. The front end is fuel rich and consequently has lower flame temperatures. The dilution or quench region is characterized by peak gas temperatures as the fuel-rich mixture transitions through stoichiometric fuel–air ratio to the fuel-lean conditions at the combustor exit. In the front end, smoke is formed due to the combustion at fuel-rich conditions. Some of the smoke formed in the front end is oxidized in the high-temperature, oxygen-rich quench region. Thus, the front-end airflow level must be set with understanding of the formation and oxidation processes. The NO_x emissions are formed in both the front end and quench regions at high power. NO_x formation is exponentially a function of gas temperature, but also depends on the residence time at the local temperature. The highest rate of formation occurs in the quench region since it is the region where peak temperatures occur. However, time at peak temperature in the quench region is relatively short due to high mixing rates. In contrast, the formation of NO_x in the front end is not negligible since it has relatively longer residence time due to the flow recirculation. The presence of cooling flow in the front end also leads to NO_x formation when it interacts with the fuel-rich gas mixture.

Recent advances have shown that substantial reductions in residence time and NO_x can be achieved without compromising combustor stability and low-power performance. Use of fuel injectors that produce small droplets uniformly dispersed within the air flow and rapid air jet mixing has enabled the residence time reduction. These

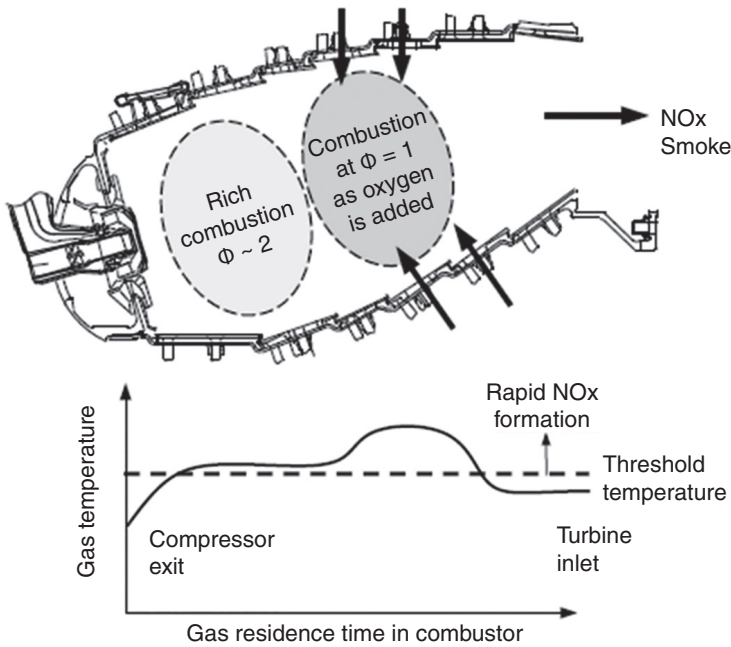

Figure 1.8 Combustor at high power.

advanced RQL combustor designs (Figure 1.9) have demonstrated NO_x reduction of over 50% when compared to early annular combustors. They are also shorter and have lower volumes in order to reduce residence times. Reduced-length combustors are lighter and also have reduced surface area requiring film cooling. Advanced cooling schemes have been deployed to minimize NO_x emissions and temperature streaks into the turbines.

Overall, the RQL combustor has demonstrated excellent service history. Since it does not require complex controls to modulate fuel between injectors, it has demonstrated very good reliability. It also has inherently favorable stoichiometry for stability since the front-end airflow is minimized for NO_x control purposes. The front-end airflow is established as the minimum amount required for smoke control. If the fuel–air ratio range between high power and low power is large, the airflow required to control smoke can be larger than desirable for flame stability during decelerations. In these instances, the selected minimum transient fuel–air must be raised to protect flight safety and reliability. In turn, raising the minimum fuel–air ratio limit increases the time required to decelerate the engine, and can result in a safety risk during emergencies. If the deceleration time cannot be met with the revised minimum fuel–air ratio, then stability must be addressed by other means, such as by clustering fuel injectors that are provided with either more fuel or reduced airflow. This zone remains above the weak extinction level locally and protects against flameout at worst-case deceleration conditions.

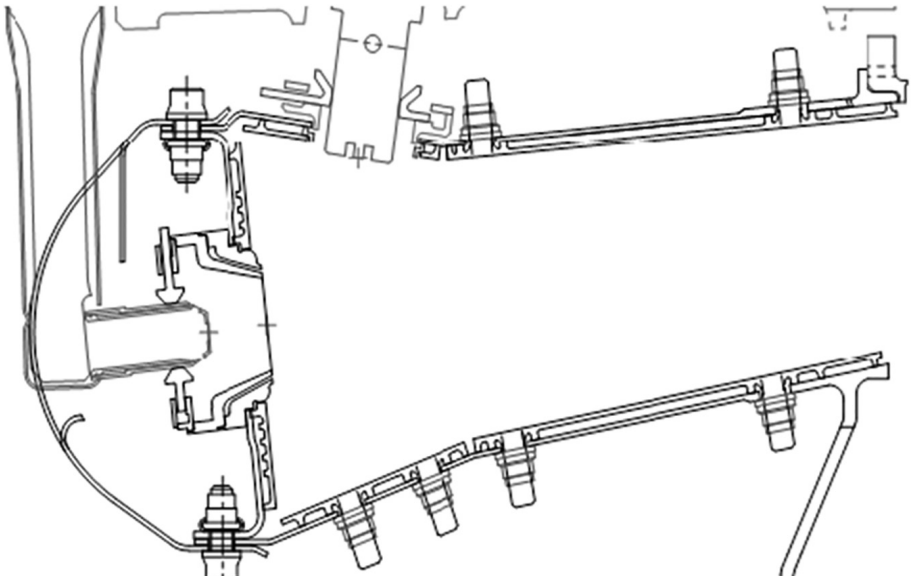

Figure 1.9 Advanced RQL combustor (Pratt & Whitney PW1500 TALON X).

The critical challenges for the RQL design approach are smoke and liner durability. As previously discussed, uniform mixing of fuel and airflow in the injectors can result in reduced smoke levels. When the fuel injector stoichiometry is fuel rich overall, the uniformity of the fuel–air distribution within the injector becomes critical. A poorly mixed injector with a wide distribution will have regions that range from fuel lean to very fuel rich. The latter can produce the bulk of the smoke in the combustor. This occurs since the highest smoke generation often occurs in the most fuel-rich regions where there is sufficient residence time. Since the front end is designed with gas recirculation to achieve stability, these zones can produce smoke. Thus, the mixing and recirculation patterns are critical to smoke control.

The presence of fuel-rich and stoichiometric gases also present a liner durability challenge. Since modern gas turbines operate at high temperatures and pressures, peak gas temperatures can exceed 4200°F. Metallic liners have a practical temperature limit of <2000°F for designs that meet typical durability life requirements. Therefore, the liner must be cooled to prevent failure. Virtually all aero engine combustors feature hot side film cooling. Film cooling provides a protective layer of airflow on the liner surface that prevents convective heat transfer from high-temperature gas. However, when fuel-rich gases in the front end interact with cooling, the film air provides oxidant for high-temperature combustion. Therefore, the presence of cooling air increases NO_x formation in the forward portion of the combustor. In the aft section of the combustor, cooling does not readily mix radially and therefore decreases gas temperatures near the walls. The result is higher temperatures in the midstream. The midstream-peaked temperature profile also increases the hottest streak temperature

exiting the combustor. Therefore, aft cooling airflow affects the temperature profile and uniformity entering the turbines. Consequently, it is desirable to reduce cooling throughout the combustor. Improved liner designs have improved heat transfer efficiency, enabled emissions reductions, and improved turbine durability. The evolution of liner cooling designs will be discussed in a later section.

1.5.3 Fuel-Staged Combustors

Having discussed RQL approaches, we next consider fuel-staged combustors, which have seen limited use in commercial aircraft service. First-generation designs were introduced in the 1990s and updated designs are scheduled for release in future engines. The overall approach in a fuel-staged combustor is to control the combustion stoichiometry through the use of fuel injection in multiple locations. Where the fixed-geometry RQL combustor injected fuel and air as uniformly as possible in the front end of the combustor, the staged combustor deliberately provides for multiple airflow and fuel-flow zones. The objective is to achieve fuel-lean combustion conditions for NO_x reduction at high power. The fuel-lean conditions keep gas temperatures low and virtually eliminate the highest temperatures associated with stoichiometric conditions that exist in the RQL design.

The lack of fuel-rich and stoichiometric combustion creates two immediate benefits when compared to an RQL design. The first is that the fuel-lean flame produces very low levels of soot emissions. This means that carbon particulate emissions have the potential to be lower from fuel-staged combustors. Significant future efforts are required to characterize the full range of particulates emitted from both types of combustors. The second benefit is that the staged lean combustor requires less film cooling air for the liner. Since the lean reaction produces less soot, it is less luminous, resulting in reduced radiation heat load on the liner. Additionally, since the peak gas temperatures are lower, the convective heat loading is reduced. These factors allow for reduced liner cooling flux. This air can in turn be used for emissions control or to improve combustor exit temperature uniformity.

In a fuel-staged combustor, a large amount of airflow is mixed with the fuel at the injection point, so that fuel-lean conditions are achieved at high power with all fuel injectors flowing. The large amount of airflow and fuel-lean conditions pose a stability challenge at low power due to the fuel–air ratio lapse that occurs between high power and low power. To mitigate the stability risk, some of the fuel injectors are turned off at low power. This allows for the control of the combustion stoichiometry at idle to ensure high combustion efficiency. The zone that operates at low power is referred to as the pilot zone, and the high-power fuel injectors are referred to as the main zone. A difficult challenge for staged combustor designs is the transition between operating with only the pilot at low power and all fuel injectors at high-power conditions. The transition often occurs at mid-power conditions such as approach thrust where fuel–air ratio, pressure, and temperature are not as high as cruise climb and take-off. Therefore, the local fuel–air ratio in the main stage may be unfavorable for efficient combustion at the lower temperatures and pressures. Consequently, more complex

staging systems may be required where the main-stage fuel injectors are turned on at different overall fuel–air ratios so that high efficiency is maintained. These fuel–air ratios are referred to as staging points. Initial designs were applied to engines with relatively low fuel–air lapse levels. These designs were operated with two fuel stages and a single staging point. More recent designs applied to engines with higher fuel–air ratio lapse may require more than a single fuel staging point to maintain staging efficiency.

Staging can also affect engine acceleration time from idle to higher power conditions. This is due to two factors. The first is the aforementioned combustion efficiency near the staging point. Lower efficiency results in reduced heat release and slower acceleration. The second is potential delay time to deliver fuel to the main fuel injectors. If some of the fuel flow is needed to fill fuel manifolds and fuel injectors, there will be a delay in the time to achieve combustion heat release and engine acceleration. Therefore, it is desirable to keep the main-stage fuel system as filled as possible to achieve prompt acceleration when the throttle is moved. However, a full main-stage fuel system is vulnerable to fuel coking. Fuel coking refers to the hard carbonaceous compounds that are formed in the internal passages of the fuel system when the fuel undergoes pyrolysis reactions when it is heated in the absence of air. Such compounds can block or reduce the flow of fuel through the main-stage hardware. Coking is most common inside the fuel injectors since they are exposed to the high temperatures inside the diffuser casing. In the extreme, coking can limit thrust by limiting fuel flow. Most modern engines have idle air temperatures near or above the level at which significant coking occurs (400°F). This air is in contact with the main-stage fuel injectors containing the stagnant fuel. To prevent fuel coking, cooling and insulation features must be incorporated to prevent fuel from contacting passage walls over the critical temperature for coking. Some designs use the pilot fuel flow to cool the stagnant main fuel injectors. Other possibilities include using air pressure to purge the fuel from the most vulnerable areas.

A last challenge to the fuel-staged combustor designer is combustion instability. Combustion instability refers to temporal fluctuations in the heat release. Such fluctuations can be attributed to several mechanisms, typically involving excitation of natural fluid mechanic instabilities in the flow or fuel–air ratio oscillations. In the extreme, instabilities can damage hardware and result in engine damage and failure. All combustors have the risk of instability; however, staged lean combustors have been more prone to them. It is unclear if this tendency is related to differences in acoustic driving resulting from heat release distribution differences or perhaps due to changes in acoustic damping as the combustor is modified for lean staged operation (T. C. Lieuwen and Yang, 2005).

1.5.4 Ignition and Engine Starting

Gas turbine combustors are required to ignite on the ground and in flight. Ignition in flight is rare since it occurs after unplanned engine shutdown. The combustor should ignite promptly after the fuel is turned on and provides efficient combustion to accelerate the engine to idle power. Delayed ignition can cause excess fuel accumulation in the combustor

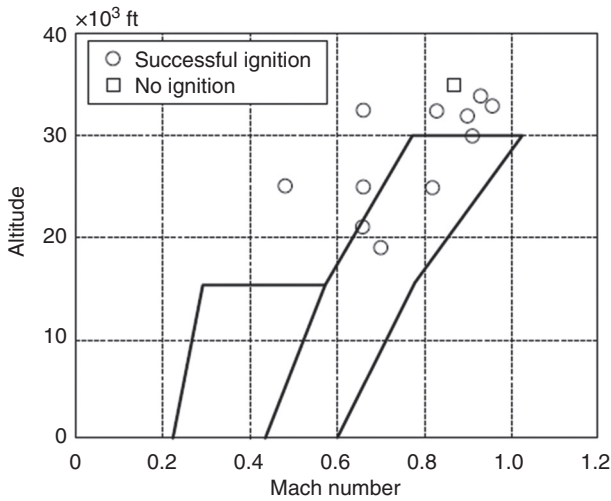

Figure 1.10 Altitude relight envelope (B777 with PW4084 engine).

and increased pressure pulses at light off. Increased pressure pulses can result in compressor stall that prevents engine acceleration to idle. On the ground and at low speed flight conditions, the engine rotors are turned with a starter to provide airflow to the combustor for ignition and combustion. At higher speed flight conditions, the ram airflow turns the rotor in a process referred to as windmilling. Ignition energy is typically delivered with a spark igniter. At least two igniters are placed in the typical annular combustion chamber to provide redundancy in the event of a failure. The spark produces plasma sufficient to initiate the combustion reaction. The ignited reactants must then be transported to an area where the reaction can stabilize and propagate to the other fuel injectors in the combustor. The same features that provide for flame stability at idle and deceleration conditions are relied upon at sub-idle starting operations. The pressure at light off is usually near the outside ambient pressure since the rotors are not producing significant work. However, at higher flight speeds, the total pressure is typically slightly higher than ambient due to the stagnation effect. Temperatures at ignition are highly dependent on the thermal state of the engine. For the first start of the day on the ground, temperatures are usually only slightly higher than ambient. Altitude relight temperatures are highly dependent on the amount of time the engine has been shut down. For quick relight attempts less than a minute after shutdown, temperature at the combustor inlet can be greater than 200°F. If the engine is shut down and windmilling for 30 minutes or longer, the air temperature is closer to the outside ambient.

Most commercial aircraft have requirements for both ground and altitude starting. The ground starting requirements include a range of ambient temperatures and airport altitudes. Typical ground starting ambient temperature requirements are between -40 and 120°F. Airport altitude requirements typically range between sea level and 8000 feet. Altitude relight requirements are typically expressed on a flight envelope (Figure 1.10). There is a high-speed windmilling envelope and a lower speed starter assisted envelope. The maximum altitude required for air starting depends on the aircraft. Commercial

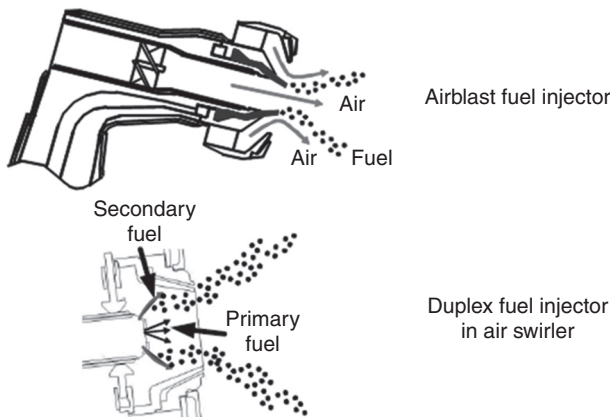

Figure 1.11 Fuel injector types.

airliners normally require altitude relight capability of at least 25,000 to 30,000 feet. Business jets often require capability at 35,000 feet due to their higher cruising altitude.

At the highest altitudes and in extreme cold, combustor ignition conditions can be very challenging. Pressures of less than 5 psia and temperatures below 0°F are typical for an engine that windmills until cold. These conditions inhibit the atomization of fuel and vaporization of droplets. Low temperature and pressure also slow the reaction kinetics that promotes stabilization and propagation of flame. Therefore, design of the combustor should provide for three key features that enable ignition. They are a good fuel spray, a favorable airflow velocity, and the proper spark igniter location.

Small fuel droplets are critical to the formation of vapor that is necessary for ignition. Two types of fuel injectors are typically used: pressure atomizing and airblast atomizing (Figure 1.11). The former uses high pressure to push fuel through a small orifice to generate the spray. The fuel can also be swirled prior to the orifice to provide angular momentum that produces a spray cone. Airblast atomization uses the energy of the airflow to produce the spray. The fuel is typically delivered to a cylindrical surface that is between two swirling air streams. The cylindrical surface develops a thin film of fuel by the action of the swirling inner air stream. As the thin film reaches the tip of the cylinder, the shear between the two airstreams atomizes the film into a spray. Airblast atomizer performance degrades as the air pressure drop decreases and should not be used if insufficient airflow is available to atomize the fuel. This occurs when windmill ignition is attempted at very low airspeed and when insufficient starter torque limits rotor speed in assisted starts. Often, airblast fuel injection systems will be supplemented with pressure atomizers in the locations where the igniters are placed. Such injectors that incorporate both pressure atomizing and airblast features are referred to as hybrid or duplex injectors. Increased fuel flow at the igniter locations can also be provided to help achieve ignition. This additional nonuniform fuel flow is provided by upstream valves and is usually only present at low-power settings. Manifolds that deliver the fuel must be designed such that the desired distribution of fuel is achieved.

Successful ignition also requires a favorable velocity in the region near the spark plug and the stabilization zone. Since most combustors are swirl stabilized, the recirculation of flow can be used to transport the ignited spark kernel to the stabilization zone. However, even a properly designed stabilization zone can result in poor ignition characteristics. This can be due to two factors. The first is local velocities that are too high to sustain the reaction surrounding the spark. This results in the convective heat loss from the reaction kernel exceeding the heat released by the reaction, quenching the reaction. This situation is created when there is insufficient volume and cross-sectional area in the stabilization zone for the quantity of airflow present. Therefore, care must be taken to ensure that local velocity does not exceed the flame propagation speed at light-off conditions. The other cause is improper igniter placement. If the igniter is placed in an area with flow direction away from the recirculation zone, the reaction kernel can be carried out at the back end of the combustor. Igniters also must be placed in an area where the fuel spray provides sufficient local fuel–air ratio to achieve ignition. Conditions at ignition are often relatively high in overall fuel–air ratio due to low airflow levels, but there are wide variations in local fuel–air ratio. As a result, spark igniters are often placed at the downstream edge of the flow recirculation such that it receives robust fuel–air mixture from the conical fuel spray, but also provides reverse flow direction for stabilization.

1.6 Turbine and Combustor Durability Considerations

The combustor has a significant impact on turbine durability and consequently impacts engine performance. The temperature distribution at the combustor exit affects the cooling airflow required to protect the airfoils and platforms in the turbines. This cooling airflow, in turn, reduces the engine performance by diverting flow from the mainstream so that it is not used to produce work. The cooling also causes mixing losses if it is introduced as low momentum film on the airfoils. Combustor film cooling is required for aero engines since the metallic liners are exposed to the high temperature combustion process. Combustor cooling itself does not affect engine performance since it is added upstream of the turbines. However, combustor cooling does reduce the amount of airflow available to control emissions and mix out temperature streaks. Therefore, it is desirable to minimize the amount of cooling flow used.

As previously mentioned, the combustor exit temperature distribution has a large impact on the amount of turbine cooling required and, thus, the engine performance. Combustor exit temperature quality is normally described in terms of the radial average temperature profile and the hottest streak intensity. These are referred to radial profile factor and pattern factor, respectively. They are typically described as non-dimensional parameters: radial profile factor = $(T_{ra} - T_e)/(T_e - T_i)$, where T_{ra} is the average temperature at a given radial position, T_i is inlet temperature, and T_e is the mass averaged exit temperature. The pattern factor is given by pattern factor = $(T_{str} - T_e)/(T_e - T_i)$, where T_{str} is the maximum temperature anywhere in the combustor exit annulus, commonly called the streak temperature.

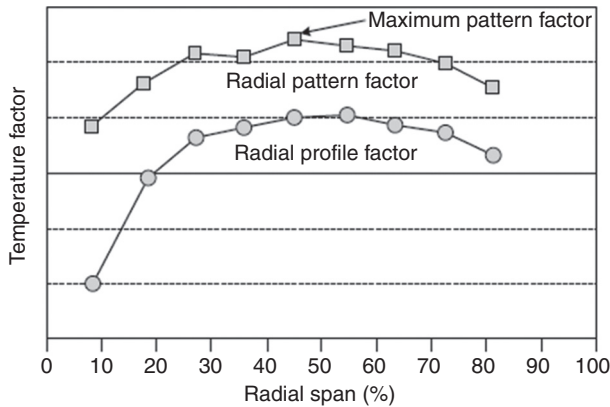

Figure 1.12 Combustor exit profile and pattern factor.

The radial profile factor is determined as a function of radial position at the entrance to the turbine. The maximum pattern factor occurs at only one spatial position in the combustor exhaust (Figure 1.12). Often this location is the result of random hardware variation and cannot be assumed repeatable from engine to engine. However, the radial distribution of pattern factor is also of interest to the turbine designer. Turbine static hardware (vanes and outer air seals) are impacted by the local gas temperatures while rotating blades are impacted predominantly by the radial average temperature profile since they rotate too fast for metal temperatures to respond to local effects. Thus, the static hardware cooling level is often set to protect against the hottest pattern factor streak, even though it occurs in only one place. This is why it is useful to know the radial distribution of pattern factor so that static hardware cooling can be distributed more in the core region, where the hottest streak is likely to occur, and less near the walls where the average temperatures are lower due to the effects of combustor cooling.

To achieve the target radial temperature profile and low pattern factor, the designer must control the mixing of fuel and air in the combustor. To achieve the lowest possible pattern factor, the designer would premix all of the airflow with the fuel at the combustor front end. This would produce a flat, uniform temperature profile at the combustor exit. However, considering liner cooling requirements, operability, and radial profile requirements, this approach is not practical for aero engines. In practical aero engine designs, cooling air is injected into the combustor in a way such that it provides a protective film near the combustor walls. As such, it generally does not mix readily with the other air streams and the fuel in the combustor. Liner cooling is therefore not effective at controlling pattern factor, but can be effective at providing cooler radial average profile near the inner and outer walls. The airflow not used for liner cooling is used to control radial profile shape and pattern factor. In RQL designs, the bulk of the non-cooling airflow enters through air jets downstream of the front end in the liner walls. In fuel-staged designs, most of the airflow is incorporated into the fuel injection swirlers at the front end of the combustor. Therefore, the mixing

processes to achieve uniform exhaust temperatures are quite different. In swirling flow mixers, multiple air streams are often used to create shear layers that promote mixing. Fuel is injected into the air streams so that it is dispersed and mixed with the air. Fuel injection is usually accomplished with jets, thin films, or pressure sprays. Swirling airstreams may be co-swirling or counter-swirling. Both approaches have been successfully used. Counter-swirling airstreams produce the highest mixing rates, but result in low net swirl if not designed with unequal flow quantities. These principles are applied to both RQL and lean-staged designs since good fuel injector and swirler mixing are required for both design approaches.

The penetration of the jet can be controlled by the sizing, pressure loss, and upstream flow quantity. Efficient mixing of upstream gases also requires jet spacing that is dense enough to mix within the combustor length allocated. Therefore, the arrangement and size of the jets are critical to the spatial delivery of airflow to the critical regions where it is needed to mix temperature streaks and provide target radial average temperatures.

Staged lean combustors may only use air jets to control radial profile shape, since the lean well-mixed front end delivers good pattern factor at high-power conditions. For example, a row of smaller holes in the aft end of the combustor can effectively cool the inner portion of the radial distribution due to their limited penetration. At low-power conditions, staged lean combustors often have worse uniformity due to the reduced number of fuel injectors operating. RQL combustors are more dependent on the jet mixing to deliver both the radial profile and pattern factor targets. Numerous experimental studies have been conducted to determine the optimum jet arrangement for mixing flow in a duct (Holdeman, 1993). For combustors where the upstream flow is swirling, computational fluid dynamics analysis is useful to refine the distribution. Rig testing is required to determine the maximum pattern factor since CFD calculations typically cover a single fuel injector sector, and thus do not provide random effects.

Combustion imposes two different types of heat loads on the liner. The first is radiation from the flame to the surfaces. The second is the convective effect of hot gases contacting the liner cooling films. The convective load can result in film temperature that is above metal temperature in some areas of the combustor. The radiation flux is given by: $q_r = 0.5(1 + \epsilon_w)(\epsilon_g T_g^4 - \alpha_g T_w^4)$ where ϵ_w is the wall emissivity, ϵ_g is the gaseous emissivity, α_g is the gas absorptivity at the wall temperature T_w , and T_g is the radiating gas temperature. The gaseous emissivity is dependent on the flame luminosity and gas temperature, which in turn depends on the combustion stoichiometry. Rich combustion tends to produce soot that is highly luminous. Therefore, the forward section of a RQL combustor tends to have more radiant heat load than a staged lean combustor, which produces very little soot. The mid-section of a RQL combustor produces peak gas temperatures as the stoichiometry transitions from fuel rich to fuel lean. This region of a RQL also has higher gaseous emissivity than a lean-staged combustor does.

Convective heat load on the liner is dependent on the local gas temperature and velocity and its interaction with the cooling film. The effectiveness of the film is

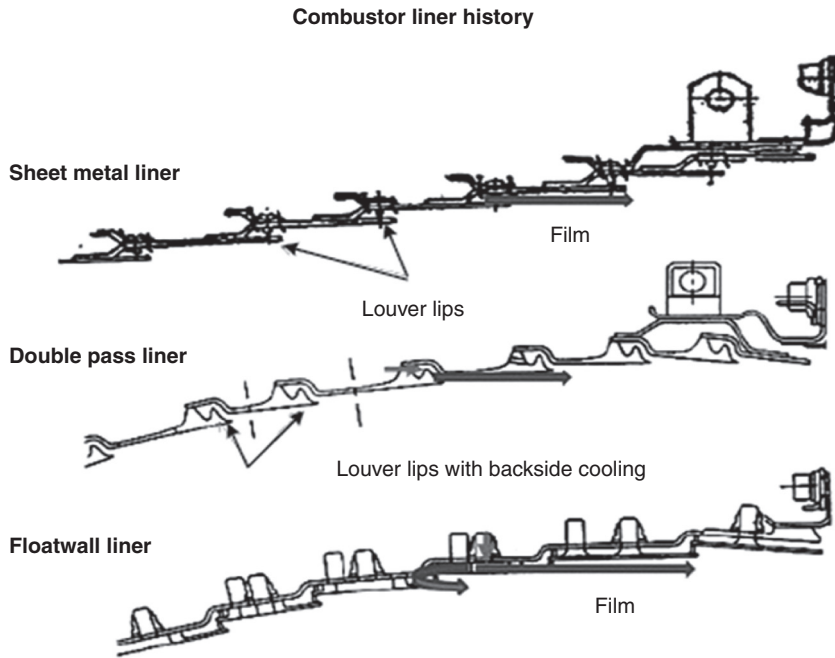

Figure 1.13 Liner cooling designs.

critical to maintenance of acceptable metal temperatures since the film temperature is a key driver in the heat flux: $q_c = h(T_{\text{film}} - T_{\text{metal}})$ where q_c is the convective flux, h is the convective heat transfer coefficient, T_{film} is the film temperature, and T_{metal} is the liner surface metal temperature. Film temperature is dependent on the local gas temperature and film effectiveness. Film effectiveness depends on the nature of the film (slot flow, discrete holes, etc.) and the ratio of the cooling momentum to the mainstream flow momentum. The momentum ratio is referred to as the blowing parameter. In zones where the mainstream flow momentum is low and the blowing parameter is high, the cooling film effectiveness is reduced. This occurs most commonly in the front end of the combustor. Note that for equivalent film effectiveness, the RQL design will have higher film temperature since it reaches higher peak gas temperature than the staged lean combustor.

Cooling strategies for the outside of the liner wall vary widely with design (Figure 1.13). Outside cooling is important since it balances the hot side heat flux. With high backside cooling effectiveness, higher hot side heat flux can be tolerated. Initial liners made use of simple louvers which created slot films on the liner hot side and had minimal heat transfer on the outside of the liner wall. The louver length was determined by the distance that film effectiveness could be maintained. Louvered designs later evolved to incorporate more effective backside cooling strategies for the louver lips. All continuous ring louver liners fail due to thermal fatigue cracks. The cracks result from high thermal stresses on the full ring hoop. As operating temperatures increased,

more effective liner designs were required since cracking was an even more severe problem. This led to tiled liner (floatwall) combustors that have a cold structure that carries mechanically attached panel tiles. The cold carrying structure virtually eliminates the hoop stresses that caused fatigue cracks in prior designs. The tiles have multiple fin structures to augment convective heat transfer incorporated on the backside. Film cooling air is first passed through these fins to provide high effective heat transfer levels. More recent designs have relied on film cooling holes to increase liner cold side heat transfer rates.

RQL design typically requires a higher cooling flux than a staged lean type design. However, this difference is only significant if it prevents the achievement of other objectives. Cooling air generally stays near the liner walls of the combustor. It causes the exit temperature profile to be cooler near the walls and more peaked at the mid-span of the exit plane. This is generally desirable for turbine durability since it reduces heat loading on the turbine platforms and seals. Using modern liner cooling technologies, the cooling flow allocation has not limited the achievement of profile and pattern factor targets in either type of combustor design. However, cooling can have a significant impact on emissions and combustion stability.

Cooling affects emissions most significantly at low power when the inlet air temperature is lowest. At low temperatures and fuel–air ratio, liner film cooling can quench the near-wall combustion process, resulting in the generation of UHC and CO. This occurs predominantly in the front end of the combustor where swirling and recirculating flow contacts liner film cooling. These effects occur in both RQL and lean-staged designs. In the extreme, this local quenching can result in loss of flame stability if the heat released is not sufficient to sustain continuous ignition. At high power, cooling can result in the formation of NO_x emissions in the front end of RQL combustors. The NO_x forms when fuel-rich front-end gases contact film cooling. The region where the contact occurs produces stoichiometric combustion temperature and the highest NO_x formation rates. In lean-staged combustors, the cooling air does not increase NO_x since the fuel–air mixture is already leaner than stoichiometric and cooling causes a reduction in combustion temperature.

Future aircraft engine cycles will require improved thermal and propulsive efficiency in order to meet aggressive fuel burn goals and address CO₂ emission concerns. Current cycles have sufficient differential between the coolant and target metal temperatures to allow effective cooling within allowable flow budget. As cycle temperatures increase, improved liner cooling technology or increased temperature materials will be required to maintain low enough cooling fluxes to meet all combustor metrics.

1.7 General Description of Jet Fuel Characteristics and Properties of Interest

Understanding the physical and chemical properties of aviation fuels is necessary to design a combustor with the necessary characteristics that can meet all the engine requirements. The design and performance of jet engine combustors and fuel systems

Table 1.2 Typical transportation fuel properties (adapted from Edwards, 2020).

	Jet fuel	Diesel fuel	Automobile gasoline
Density (kg/m ³)	805	850	740
Avg. molecular weight (kg/k-mole)	160	210	95
Carbon number range	C8 to C16	C9 to C23	C4 to C10
Flash point (°C)	50	60	
Freeze point (°C)	−52	−18	
Volume average boiling point (VABP)	210	275	105

must consider the properties of the fuel, and the necessary design trades that must be made to ensure a safe, dependable, and robust design. As the aviation industry considers changes to the fuels used for transportation, the combustor designer must be cognizant of the changes in physical and chemical properties of the fuel under consideration.

Only a superficial overview of the properties will be discussed here. The reader is encouraged to review Edwards (2020), Coordinating Research Council (1983), and the references therein for comprehensive details of jet fuels and fuel properties. A comparison of typical transportation fuels is shown in Table 1.2.

1.7.1 Fuel Composition

Jet fuels can be derived from multiple sources. The most common source is from the petroleum refining process; however, jet fuel can also be extracted from coal, natural gas and as the world tends toward a carbon neutral future, bio-derived feedstocks (see Chapter 7). Aviation fuels can generically be referred to as kerosene and made up of literally hundreds of different hydrocarbon molecules. Comprehensive standards such as ASTM D1655 and Defense Standard 91-091 define the composition and physical property limits for various grades of aviation turbine fuels (D1655, 2010). The hydrocarbons fall into general classifications, including aromatics, alkanes, alkenes, and cycloalkanes. Other organic molecules in the jet fuel may contain organically bound nitrogen, sulfur and/or oxygen. The standards only place limits on aromatics and sulfur-containing molecules. In the example of Jet-A, the composition is limited to an aromatic concentration maximum of 20% by volume, and a total sulfur mass of 0.3% with a mercaptan sulfur of 0.003%. However, these and the balance of the other hydrocarbons in the final blend must meet the specification of the physical properties. This gives flexibility to refineries with varying feedstocks to meet the full specification for the fuel. For readers interested in the detailed chemistry of the fuels and classes of hydrocarbons refer to Schobert (2013).

The physical properties of hydrocarbon fuels are set by the final blended mixture of hydrocarbons. The molecular weight of the constituents and the class of compounds control the properties of the mixture, which vary as a function of pressure and temperature. The class of compounds have the general influence on the fuel as highlighted in Table 1.3 from Holladay et al. (2020).

Table 1.3 Fuel properties – molecular structure relationship

		<i>n</i> - alkanes	Iso- alkanes weakly branched	Iso- alkanes strongly branched	Cycloalkanes monocyclic	Cycloalkanes fused bicyclic	Aromatics
Performance	Specific energy	++	++	++	+	0	–
	Energy density	–	–	–	+	++	++
	Thermal stability	+	+	+	+	+	
Operability	Sooting	++	++	++	+	+	—
	DCN	++	+	–			–
	Density	–	–	–	+	++	+
	Freeze point	–	+/-	+	+	+	+
	Sooting	++	++	++	+	+	—

Historically, the largest concern for the combustion design engineer has been in minimizing the amount of nonvolatile particulate matter (nvPM) carbon particulates or soot, which is a strong function of the amount of aromatic class of compounds found in the jet fuel. ASTM D1655 limits aromatic content to 20% by volume, but all the current aviation fuels typically range between 5% and 25%. From a fuel system standpoint, the aromatic compounds help ensure proper swelling of the nitrile elastomer seals. This appears especially true if the system containing nitrile seals was previously exposed to fuels with relatively high aromatic concentrations (Holladay et al., 2020). Aromatic compounds contribute to higher energy density, higher mass density, and reduce the freezing point of the fuel. Alkanes tend to decrease the density and the energy density of the fuel. Additionally, they may elevate the freeze point, as the normal paraffins are the first molecules that start solidification as the fuel temperature drops.

1.7.2 Density

Density (ρ , kg/m³) is the mass per unit volume. Density is important in the design of gas turbine combustors and fuel system design to estimate the aircraft fully fueled weight and the range capability based upon the gas turbine fuel efficiency or total specific fuel consumption (TSFC). The density of the fuel is important for the design calculations of flow, fuel metering and measuring devices, fuel loading, thermal expansion of the fuels, and fuel tank design. Rigorously, density is a function of temperature, pressure, and composition (Smith et al., 2018). However, for jet fuels, density is predominantly a function of temperature, and approximately linear over the temperature range of interest with a negative slope (Coordinating Research Council, 1983; Edwards, 2020).

1.7.3 Viscosity

Dynamic viscosity of the fuel (μ , Pa-s) physically represents internal resistance to motion caused by cohesive forces among fluid molecules. Kinematic viscosity

($\nu = \mu/\rho$, m^2/s) is defined as dynamic viscosity divided by density for convenience of many calculations. Most jet fuels are Newtonian in nature, that is, the shear stress is proportional to the velocity gradient. Viscosity of the fuel controls the pressure drop, influences the fuel system design, and plays a role in the atomization process. Because jet fuels are multicomponent mixtures, at low temperatures the fuel does not undergo a simple liquid to solid transition. Rather, the higher molecular weight species begin to freeze first, and often this is characterized by a pour point, a wax point, cloud point, or freeze point of the fuel. Jet fuel specifications place limits on low temperature viscosity of the fuel (Edwards, 2020). Additionally, near these conditions the deviation from Newtonian behavior can be observed leading to unexpected increases in pressure drop, and/or creates challenges for the atomization of the fuel, which can impact altitude lighting and cold ground starting.

1.7.4 Surface Tension

Surface tension (σ , N/m) is defined as the specific free energy of a liquid surface at the interface with another fluid. Physically, surface tension is a property of the liquid, and must be overcome by aerodynamic forces to achieve atomization of the fuel (see Lefebvre and McDonald, 2017). Often for jet fuels, surface tension is reported for the liquid surface in contact with air, but it can be reported for being in equilibrium with the vapor. The combustor designer is concerned with the atomization characteristics of the fuel which can impact the ignition, mixing, and flame stabilization of the fuel within the combustor. Surface tension decreases as the temperature increases and cohesive forces overcome. In general, higher molecular weight and higher density fuels have higher surface tensions at the same temperature. For a given fuel nozzle and flow conditions, surface tension controls the droplet size distribution, which controls the surface area available for evaporation and mass transport from the liquid phase to the gas phase. The gaseous fuel subsequently mixes with the air in a jet engine combustor and reacts with oxygen releasing heat.

1.7.5 Specific Heat

The specific heat or heat capacity (kJ/kg-K) of a fuel is the amount of enthalpy (C_p) or internal energy (C_v) required to raise a unit mass of the fuel by a unit of temperature. The aircraft system often requires the fuel to be used as a coolant or heat sink. The specific heat of the fuel determines to what extent the fuel can be used as a heat sink and stay within the necessary limits to ensure a robust design.

1.7.6 Vapor Pressure

For a pure substance, vapor pressure is the equilibrium pressure (P_{vap} , kPa) of a vapor in contact with the liquid, and is a single line in P, T space between the triple point and the critical point. However, for multicomponent mixtures the behavior becomes more complex (Smith et al., 2018). Therefore, properties related to vapor pressure for

hydrocarbon fuels are characterized by ASTM methods such as distillation curves and flash point (Edwards, 2020). The lower the vapor pressure at a given temperature, the greater the propensity for the liquid to be transported to the gas phase. The combustor designer is concerned with the time scale associated with the mass transport to the gas phase where mixing with the air and combustion occurs. As fuel temperature decreases vapor pressure decreases, which can affect ignition at colder conditions because enough fuel cannot be transported to the gas phase. Additionally, vapor pressure can influence the design of the fuel system. At higher temperatures, the vapor pressure of the fuel can be high and leads to cavitation in the fuel system components, resulting in reduced mass flows or premature wear of components.

1.7.7 Heat of Vaporization

The heat of vaporization (kJ/kg) is the amount of energy required to vaporize a unit of liquid fuel. For a pure component fluid, as heat is added to the fluid, the temperature remains constant as energy is used to vaporize the liquid. Like vapor pressure, the multicomponent behavior is more complex (Smith et al., 2018). Distillation curves for jet fuels show the temperature difference between the initial boiling and final boiling can be as much as 300°C (Edwards, 2020). This can be important to the combustor designer for ignition, altitude starting, and cold ground ignition.

1.7.8 Net Heat of Combustion

The amount of energy stored in fuel is released when a unit weight is burned in a bomb-type calorimeter under controlled conditions to produce gaseous carbon dioxide and liquid water containing sulfuric and nitric acids. The gross heat of combustion or specific energy is calculated from the rise in temperature. In a gas turbine engine, the products of combustion leave in the vapor phase; hence, the heat of vaporization of water as determined from the hydrogen content of the fuel is subtracted from the gross heat of combustion to determine the net heat of combustion. This value is expressed in terms of mega joules per kilogram (MJ/kg) and the volumetric heating value is in terms of mega joules per cubic meter (MJ/m³).

1.7.9 Auto-ignition Temperature

The auto-ignition temperature of a fuel is the temperature at which the fuel vapor will ignite in air at atmospheric pressure, even though an external source of ignition is not present. The auto-ignition or spontaneous ignition temperature is a function of the local fuel–air ratio and the mean droplet size for liquid fuel combustion. The closer the fuel–air ratio is to stoichiometric and the smaller the droplet size, the lower the auto-ignition temperature. For these reasons, liquid fuel injectors are designed to minimize droplet size to improve ignitability of the fuel while gaseous fuel injectors focus on mixing the gas fuel with air to improve ignitability.

1.8 Renewable Fuel Options and Impact

As the aviation industry considers carbon-neutral solutions for the future aviation markets, the fundamental problem to solve is storing the large amount of energy required to operate an aircraft with weight and volume constraints. The global consumption of jet fuel in 2019 was approximately 106 billion gallons and the demand is expected to increase to 230 billion gallons in 2050 (Holladay et al., 2020). Options that exist for energy storage in aircraft applications that have been considered in the past include batteries (Liu et al., 2019), hydrogen (Sloop, 1978), hydrogen carriers such as ammonia (Valera-Medina et al., 2021), nuclear power (Carpenter, 1961), and conventional hydrocarbons. All of the energy storage options can be completed with carbon-neutral approaches. The renewable fuel impacts to combustor and fuel system operation and design are directly related to the fuel thermophysical differences summarized in the prior section.

Figure 1.14 highlights the differences in the thermophysical properties of SAF, hydrogen, and ammonia relative to Jet A. The nominal values for Jet A, used as a reference value, are shown in the first column next to the thermophysical properties. The bar chart to the right shows the variation in thermophysical properties for aviation fuels, SAF, hydrogen, and ammonia relative to Jet A. The width of the bar shows a rapid nonlinear increase in variation relative to Jet A, which is at a zero reference at the bottom of the figure. Aviation fuels, consisting of Jet A, JP-8, JP-5, JP-7, JPTS, and JP-4/Jet B, have densities, specific heats, auto-ignition temperatures and heat of combustion on a mass basis within 6% of Jet A. As a result, fuel metering, combustor heat release, and the ignition of the same fuel–air mixtures are similar and require no changes to the combustor or fuel system. Reductions in the fuel freeze point and kinematic viscosity can improve combustor cold day ground starting. Larger differences in the aromatic content from 5% to 25% (or $-3.5\times$ lower to 43% higher levels relative to jet A) result in different sooting behaviors and highlight the opportunity to reduce particulates based upon fuel content and is one of the main drivers for SAFs.

1.8.1 Sustainable Aviation Fuels (SAFs)

The impact jet fuels have on the combustor can be split into performance and operability metrics that affect the functional characteristics of the engine. As shown in Figure 1.14, performance metrics for SAF such as the net heat of combustion fall well within the variation of aviation fuels, while their densities, specific heats, and auto-ignition temperatures remain within about 10% of Jet A. The majority of the physical and chemical properties of SAF are similar to conventional jet fuel and hence are expected to have little impact to the combustor performance; however, SAFs could impact the aircraft fuel system. These expectations must be verified with proper engine verification and validation.

The smoke/nvPM emissions performance from conventional jet fuels are already low. The largest thermophysical property changes SAF provide, shown in Figure 1.14, is the ability to reduce the aromatic content to about 1%, or $17.5\times$ lower

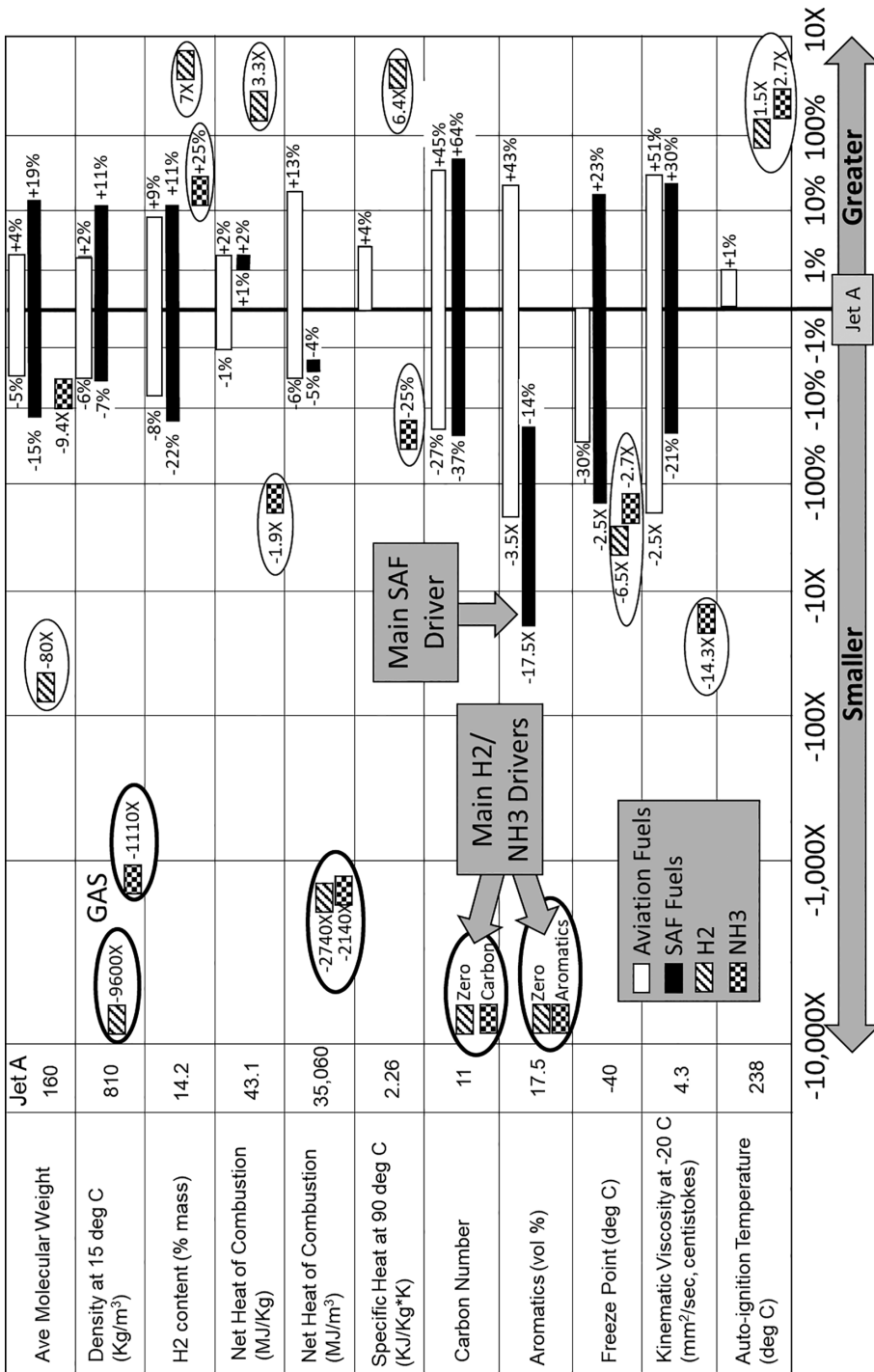

Figure 1.14 Thermophysical property comparison of SAF, H2, and ammonia relative to Jet A. Adapted from Edwards (2020) and Coordinating Research Council (1983).

than Jet A. This reduced aromatic content has been shown to reduce nvPM emissions (Mensch et al., 2010). Gaseous CO₂ emissions are expected to remain similar. Thermal stability characteristics include the freeze point which is below -40°C for jet fuels and SAF, but some SAFs have even lower freeze points, providing the additional flexibility to operate over a large range of altitudes to optimize fuel consumption. Operability metrics include those that ensure the combustor can light on the ground and relight at altitude over a wide range of pressures and temperatures and avoid combustion instabilities. The ignition and combustion process can be affected by fuel properties that affect liquid fuel atomization and vaporization and include viscosity, freeze point, flash point, vapor pressure, and surface tension. For these reasons, it is important to verify the combustor altitude relight, cold day ground starting, and lean blowout are acceptable when using 100% SAF. While SAF may have negative impacts to combustor operability, changes to the combustor fuel schedules and fuel–air distribution can manage these impacts, so the benefits of reduced particulate emissions can be realized. Little to no change is expected to the fuel system provided the fuel seals do not leak because of the low aromatic content in SAF.

In contrast to SAF, gaseous hydrogen and ammonia have the benefit of no carbon atoms and, consequently, zero smoke emissions. However, the density of these fuels in the gaseous state are $1000\times$ to $9000\times$ lower than Jet A. Cooling these fuels to a liquid state would be required to manage the fuel tank volume on the aircraft. The fuel could then be used to cool various parts of the gas turbine engine before being injected into the combustor as a gas. Because of the large density differences, the fuel system internal flow areas need to be resized and changes are required to meter and control ammonia and hydrogen fuel from startup to shut down. In many engines, the fuel system is also used to cool external components. Reductions to the hydrogen fuel specific heat by 25% or an increase in the specific heat of ammonia by $6.4\times$ may require changes or provide opportunities for the fuel system to manage these external components.

As discussed in Section 1.7, the significant increase in hydrogen content increases the auto-ignition temperature by 1.5 to $2.7\times$ for hydrogen and ammonia, respectively. While the auto-ignition temperature increase does not drive a combustor design change at low-power operation, the flame speed of hydrogen increases by $3\times$ and allows the flame to propagate upstream and remain inside fuel injectors depending upon the relative flow velocities to the hydrogen flame speed. The higher flame speeds can improve cold day ignition and altitude relight capability. Flashback or auto-ignition of hydrogen fuel–air mixtures at high power, or when air temperatures exceed the auto-ignition temperature, drive significant changes into the combustor and fuel injector design to manage stable heat release distribution within the combustor. The heat of combustion for hydrogen and ammonia on a volume basis is $2100\times$ to $2800\times$ lower than Jet A, but on a mass basis, they are within about $3\times$. The fuel flowrates need to be adjusted accordingly to produce target combustor exit temperatures. Changes to the combustor design may also be required to tailor the temperature distribution required by the turbine.

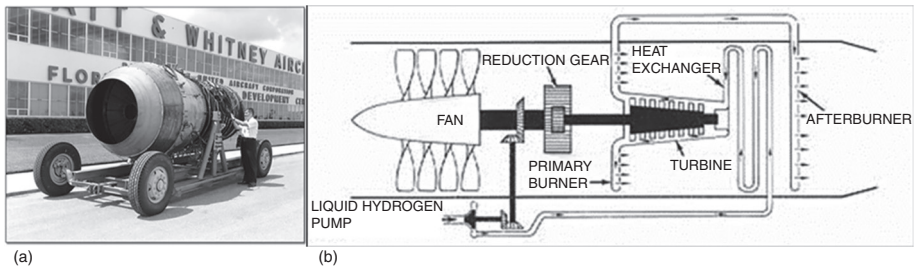

Figure 1.15 (a) Image and (b) schematic drawing of the PW 304 hydrogen fueled engine built and tested by Pratt & Whitney in 1957.

1.8.2 Hydrogen Engine Experience and Future Design Considerations

Hydrogen has been considered as a fuel for propulsion engines as early as 1945 when A. W. Lemmon from the Office of Scientific Research and Development proposed 25 fuel and oxidizer pairs for rocket engine applications (Sloop, 1978). The fuel oxidizer pair with the highest specific impulse was liquid hydrogen and liquid oxygen. Lemmon concluded that the low density of hydrogen would eliminate it from consideration. Lemmon further concluded that it was unlikely for jet engines to change from hydrocarbon fuels except for minor applications. For liquid rocket applications, the early conclusions on hydrogen were proven to be incorrect, but as of today jet engines have not utilized hydrogen beyond limited engine demonstrations.

In the mid-1950s, the need for a high-altitude reconnaissance plane was being pursued by the US Air Force, and Project Suntan produced the first Pratt & Whitney hydrogen fueled jet engine. The PW-304 engine was designed with a unique expander cycle that took advantage of expanding liquid hydrogen by the turbine (see Figure 1.15). A reduction gear coupled the fan to the turbine which was driven entirely by the heat pickup and phase change of hydrogen from liquid to gas. The engine completed combustion of the gaseous hydrogen in the afterburner to produce thrust.

In the 1950s, there were also infrastructure and supply chain challenges to produce large quantities of liquid hydrogen that need to overcome. At this time, Mark's Mechanical Engineering Handbook reported liquid hydrogen as an impractical fluid that only serves as laboratory curiosity (Sloop, 1978). Because gaseous hydrogen has such a low density its use for an aviation fuel necessitates that it be stored as a cryogenic liquid, which presents additional challenges. Another study was completed in 2009 by Adam Reiman at the Air Force Institute of Technology indicating that the costs associated with the transition to a hydrogen infrastructure would be economically sound if oil reached \$7.50 a gallon by 2029 (Reiman, 2009). His literature review highlighted the use of hydrogen in aviation from airships in 1852 to Lockheed's CL-400 prototype aircraft in 1954 to successful testing of hydrogen in a modified B-57 engine. NASA completed studies on aircraft designs that integrated liquid hydrogen tanks and Russia modified a Topolev TU-155 engine to run on liquid hydrogen that flew for 21 minutes in 1988 and defined hydrogen support infrastructure. In 1996, Lockheed Martin used a liquid hydrogen rocket-based design on the X-33 and later in 2004, NASA's X-43A hydrogen powered air-breathing ramjet engine set a new speed record of Mach 9.8.

Recently, Airbus announced ZEROe plans to develop the world's first zero-emission commercial aircraft by 2035. The fuel supply and infrastructure challenges continue to exist today for the aviation industry which are on a global scale. Today's aviation fuel energy demand is about 8.7 EJ (EIA, 2020), and this is projected to grow to 24.0 quads by 2050 (EIA, 2020). With this scale of energy usage, the entire hydrogen supply chain needs to be developed and a transition to a hydrogen-based aviation fleet will require substantial investment to produce and store hydrogen. Safety challenges that come along with storing liquid hydrogen and fueling aircraft would also have to be overcome to provide the necessary hydrogen fuel capacity to meet an industry target of zero-carbon emissions by 2050.

The likely engine cycle for a hydrogen powered aircraft will be similar in concept to the PW 304, because of the large amount of energy stored in the cryogenic liquid. The heat release within the combustor will be significantly smaller for the same thrust class. The turbine can be driven by the hydrogen expansion from a cryogenic liquid to a gas which increases the volume of the hydrogen by about 850 times. It will be necessary to utilize the energy released from the expansion of the hydrogen fuel to produce an efficient cycle. Others have proposed the use of alternate cycles for cryogenic hydrogen powered aircraft (Boggia and Jackson, 2002).

The hydrogen aircraft engine fuel system will require substantial redesign because of the large change in physical properties of hydrogen relative to Jet A. The cryogenic storage, the extraction of work from the vaporization, the ability to cool external components, and ultimately the stable and complete combustion of gaseous hydrogen require changes to many of the engine components outside the combustor.

The voluminous nature of the gaseous hydrogen compared to the liquid kerosene will require careful consideration on how to mix hydrogen with the air prior to combustion to minimize emissions while preventing auto-ignition, flashback, and flame holding at high power. The higher flame speed of hydrogen and the wide flammability limits create challenges for the combustor designer, but those properties that are different from kerosene may be utilized to improve combustor operability, such as lean blowout, altitude relight, and cold day starting. However, thermo-acoustic instabilities may present a challenge. Lieuwen et al. (2009) discuss operability challenges with hydrogen-containing fuels. The engine architecture and controls must be designed such that during startup elevated pressure spikes are avoided to prevent compressor stall and any accumulation of hydrogen in the exhaust during shutdown. Advanced diagnostics and fuel system control logic enhancements can help manage these design constraints.

A significant amount of hydrogen-fueled combustor development work has already been performed in land-based gas turbines from blends of methane and hydrogen to 100% hydrogen and will be discussed in Chapters 2, 16, and 17. Many of the hydrogen fuel challenges have been identified for research and development while combustor designs continue to maximize the percent of hydrogen they can burn (National Academies of Sciences and Medicine, 2020). It is anticipated that these lessons learned will be applied to the design of hydrogen fueled aircraft combustors that can be demonstrated on aircraft by 2035. By removing carbon from the fuel, it is clear the CO, carbon dioxide, and soot particulate emissions from the combustor will be nonexistent.

However, the fuel production supply chain may produce CO₂ emissions, and should be accounted when considering hydrogen fuels for aviation.

Very low NO_x emissions operating at very lean conditions have been demonstrated in research combustors and prototypes (Marek et al., 2005; Funke et al., 2021), but have not been fielded in an aero engine product. The NO_x benefits could be realized based on cycle efficiency gains utilizing the expansion of the cryogenic fuel to produce work without combustion. For the comparison of the combustor alone of a practical device, the NO_x emissions will depend on the operating conditions. Marek et al. (2005) correlated NO_x emissions from several lean direct injection hydrogen combustor concepts and showed a dependence on pressure, inlet air temperature, equivalence ratio, residence time, and combustor pressure drop. The NO_x results showed that hydrogen combustor emissions were similar to a Jet A fueled combustor at similar operating conditions. One possible optimization path with hydrogen fuel is taking advantage of the wide flammability limits, and therefore designing the combustor to operate at much lower equivalence ratios. Additionally, it was noted that an optimization for NO_x emissions could be done, but it would require a design trade with other requirements. As shown in Figure 1.1, the combustor performance requirements are interrelated. This is also true for a hydrogen fueled aero engine, and the combustor architecture (i.e. lean staged, RQL, etc.) and the mixing methodology (i.e. swirler, lean direct injection, etc.) will determine how to satisfy all of the requirements to make a dependable hydrogen fueled engine.

Ammonia has similar characteristics as hydrogen with some advantages with fuel storage and the disadvantage of altitude relight and ammonia slip which can occur when locally fuel-rich regions exist at low temperatures resulting in unreacted ammonia to pass through the selective catalytic reduction (SCR). This condition can also be experienced during engine startup or shutdown whereby unreacted ammonia presents an environmental and health risk. Similar to the initial development of hydrogen combustors in land-based gas turbines, which will be covered in Chapter 2, it is anticipated that ammonia fueled land-based gas turbine combustor design lessons learned will be used to develop aero-engine combustor designs that use ammonia. Successful ammonia fueled aero-engine combustors will also have to meet all the combustor- and system-level performance metrics, and these designs along with storage and supply chain metrics will be compared to those of hydrogen to meet the industry goal of zero-carbon emissions by 2050.

1.9 Summary

Gas turbine combustors remain an interesting and complex design challenge. Balancing the many requirements in an environment demanding low cost, low weight, low emissions, and excellent safety and reliability is often difficult. It is expected that operation on 100% SAF will be the next step toward reducing combustor emissions in the near term while the potential to introduce zero-carbon fuels, such as hydrogen and ammonia, will require a substantial investment into the combustor, fuel system, engine

design, and infrastructure in order to achieve zero-carbon emissions from burning aviation fuels by 2050. Many of the subjects introduced in this chapter will be discussed in more depth in subsequent chapters of this book to provide a better understanding of these issues.

References

- Air Transport Action Group. (2008). Aviation industry commitment to action on climate change. *3rd Aviation and Environment Summit*, Geneva, Switzerland, April 22. www.atag.org/component/attachments/?task=download&id=68.html
- Airbus (2021). *Environmental Matters for the Future of Aerospace*. www.airbus.com/sites/g/files/jlcbta136/files/2021-07/Environment-matters-for-the-future-of-aerospace.pdf
- American Society for Testing Materials. (2010). Standard specification for aviation turbine fuels. *Annual Book of Standards*. www.astm.org/d1655-21c.html
- Boggia, S., & Jackson, A. (2002). Some unconventional aero gas turbines using hydrogen fuel. *Turbo Expo: Power for Land, Sea, and Air*, GT2002–30412
- Carpenter, D. (1961). *NX-2 ANP Convair Nuclear Propulsion Jet*. Jet Pioneers of America.
- Coordinating Research Council (1983). *Handbook of Aviation Fuel Properties*. <https://apps.dtic.mil/sti/pdfs/ADA132106.pdf>
- Energy Information Administration (EIA), the statistical and analytical agency within the U.S. Department of Energy. International Energy Outlook 2021, Table L01, October 6, 2021. Energy Information Administration, Washington, DC.
- Edwards, J. T. (2020). *Jet fuel properties*. Air Force Research Laboratory Wright-Patterson AFB United States.
- Funke, H. H.-W., Beckmann, N., Keinz, J., & Horikawa, A. (2021). 30 years of dry-low-NO_x micromix combustor research for hydrogen-rich fuels – An overview of past and present activities. *Journal of Engineering for Gas Turbines and Power*, 143(7), 071002.
- Golley, J., Whittle, S. F., & Gunston, B. (1987). *Whittle, the true story*. Smithsonian Institution Press.
- Holdeman, J. D. (1993). Mixing of multiple jets with a confined subsonic crossflow. *Progress in Energy and Combustion Science*, 19(1), 31–70.
- Holladay, J., Abdullah, Z., & Heyne, J. (2020). *Sustainable aviation fuel: Review of technical pathways*. DOE/EE-2041 8292, USDOE Office of Energy Efficiency and Renewable Energy.
- Lefebvre, A. H., & Ballal, D. R. (2010). *Gas turbine combustion: Alternative fuels and emissions*. CRC Press.
- Lefebvre, A. H., & McDonell, V. G. (2017). *Atomization and sprays*. CRC Press.
- Lieuwen, T. C., & Yang, V. (2005). *Combustion instabilities in gas turbine engines: Operational experience, fundamental mechanisms, and modeling*. American Institute of Aeronautics and Astronautics.
- Lieuwen, T., McDonell, V., Santavicca, D., & Sattelmayer, T. (2009). *Operability issues associated with steady flowing combustors*. CRC Press.
- Liu, J., Bao, Z., & Zhang, J. (2019). Pathways for practical high-energy long-cycling lithium metal batteries. *Nature Energy*, 4(3), 180–186.
- Marek, C., Smith, T., & Kundu, K. (2005). Low emission hydrogen combustors for gas turbines using lean direct injection. *41st AIAA/ASME/SAE/ASEE Joint Propulsion Conference & Exhibit*, AIAA2005–3776

- Mensch, A., Santoro, R. J., Litzinger, T. A., & Lee, S.-Y. (2010). Sooting characteristics of surrogates for jet fuels. *Combustion and Flame*, 157(6), 1097–1105.
- National Academies of Sciences and Medicine, Engineering, and Medicine. (2020). *Advanced technologies for gas turbines*. National Academies Press.
- Reiman, A. D. (2009). *AMC's hydrogen future: Sustainable air mobility*. Air Force Institute of Technology, Wright-Patterson Air Force Base, OH, School of Engineering and Management.
- Schobert, H. H. (2013). *The chemistry of hydrocarbon fuels*. Butterworth-Heinemann.
- Sloop, J. L. (1978). *Liquid hydrogen as a propulsion fuel, 1945–1959* (Vol. 4404). Scientific and Technical Information Office, National Aeronautics and Space Administration.
- Smith, J. M., van Ness, H. C., Abbott, M. M., & Swihart, M. T. (2018). *Introduction to chemical engineering thermodynamics*, 8th ed. McGraw-Hill Education.
- Valera-Medina, A., Amer-Hatem, F., Azad, A. K., Dedoussi, I. C., de Joannon, M., Fernandes, R. X., Glarborg, P., Hashemi, H., He, X., Mashruk, S., McGowan, J., Mounaim-Rouselle, C., Ortiz-Prado, A., Ortiz-Valera, A., Rossetti, I., Shu, B., Yehia, M., Xiao, H., & Costa, M. Review on ammonia as a potential fuel: From synthesis to economics (2021). *Energy & Fuels* 2021. 35(9), pp 6964–7029.