

Equilibrium measures for two-sided shift spaces via dimension theory

VAUGHN CLIMENHAGA  and JASON DAY 

Department of Mathematics, University of Houston, Houston, TX 77204, USA

(e-mail: climenha@math.uh.edu, jjday@uh.edu)

(Received 20 September 2023 and accepted in revised form 13 May 2024)

Abstract. Given a two-sided shift space on a finite alphabet and a continuous potential function, we give conditions under which an equilibrium measure can be described using a construction analogous to Hausdorff measure that goes back to the work of Bowen. This construction was previously applied to smooth uniformly and partially hyperbolic systems by the first author, Pesin, and Zelerowicz. Our results here apply to all subshifts of finite type and Hölder continuous potentials, but extend beyond this setting, and we also apply them to shift spaces with synchronizing words.

Key words: symbolic dynamics, dimension theory, equilibrium states

2020 Mathematics Subject Classification: 37D35 (Primary); 37B10, 37C45 (Secondary)

1. Introduction and main results

1.1. *Background.* In the study of hyperbolic dynamical systems, thermodynamic formalism allows us to identify certain *equilibrium measures* whose ergodic and statistical properties provide insight into the underlying dynamics. Given a compact metric space X , a continuous map $f: X \rightarrow X$, and a continuous *potential* function $\varphi: X \rightarrow \mathbb{R}$, an f -invariant Borel probability measure on X is an equilibrium measure if it maximizes $h_\mu(f) + \int \varphi d\mu$, where $h_\mu(f)$ is the measure-theoretic entropy.

If X is a locally maximal hyperbolic set for a diffeomorphism f , then given any two nearby points $x, y \in X$, their local stable and unstable manifolds intersect in a unique point $z \in W_{\text{loc}}^s(x) \cap W_{\text{loc}}^u(y)$. A set $R \subset X$ is a *rectangle* if for all $x, y \in R$, this point z is defined and lies in R , as in Figure 1 (in general, R may have empty interior). This provides a *product structure* on R . This paper is concerned with the behavior of equilibrium measures with respect to this product structure.

With (X, f) as in the previous paragraph, and $\varphi: X \rightarrow \mathbb{R}$ Hölder continuous, it is known that every transitive component of X has a unique equilibrium measure μ , and that there are *leaf measures* m_x^s, m_x^u such that on every rectangle, μ is equivalent to $m_x^s \times m_x^u$ [Mar70, Hay94, Lep00].

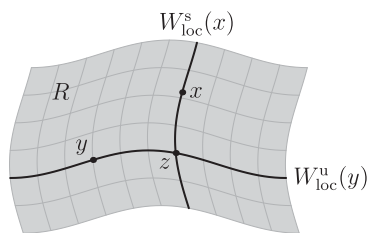

FIGURE 1. A rectangle.

It is possible to describe these leaf measures as analogues of Hausdorff measure, where the ‘refining’ in the definition of Hausdorff measure is done dynamically rather than geometrically. The idea of treating topological entropy and pressure as analogues of Hausdorff dimension goes back to Bowen [Bow73] and to Pesin and Pitskel’ [PP84]. The idea of constructing leaf measures of the measure of maximal entropy via a Hausdorff measure construction first appeared in [Ham89, Has89]; the general theory was developed by the first author, Pesin, and Zelerowicz [CPZ19, CPZ20, Cli24].

In this paper, we take some steps toward the setting of non-uniform hyperbolicity, or hyperbolicity with singularities, by considering two-sided shift spaces that are not necessarily subshifts of finite type. We give general conditions under which this dimension theoretic construction of leaf measures can still be used to construct an equilibrium measure with local product structure. Using these conditions, we obtain the following application (see §§1.2–1.4 for precise definitions).

THEOREM A. *Let X be a two-sided shift space on a finite alphabet with the specification property, and let $\varphi: X \rightarrow \mathbb{R}$ be a continuous potential function with the Walters property. Then the unique equilibrium measure μ for (X, φ) has local product structure in the sense of §1.3 below.*

Theorem A follows from Theorem 2.2 in §2.2 (see Remark 2.3), which applies to the broader class of shift spaces with synchronizing words satisfying a certain summability condition in equation (2.2). In a forthcoming paper [CD24], we will explore applications of our general results to the measure of maximal entropy for dispersing billiards that was recently studied by Baladi and Demers [BD20].

Remark 1.1. The conclusion of Theorem A can be deduced from results in the literature when X is a mixing subshift of finite type and φ is Hölder continuous [Bow08, Hay94, Lep00] or at least has the (weaker) Walters property [Wal78], and also when X has specification and φ is Hölder continuous [Cli18]. The novelty here is the ability to simultaneously weaken subshift of finite type (SFT) to specification, and Hölder to Walters, as well as to provide a framework for going beyond specification (see §2.2). Uniqueness was already known in the setting of Theorem A [Bow75], but not local product structure.

It is also worth mentioning [BO23], which establishes a certain local product structure property for equilibrium measures of non-uniformly hyperbolic diffeomorphisms with potentials satisfying a ‘Grassmann–Hölder’ continuity condition.

The main general results of this paper are the following.

- §1.5, equations (1.13) and (1.16): construction of the leaf measures m_x^u and m_x^s .
- §1.6, Theorem 1.5: conditions for leaf measures to be positive and finite.
- §1.7, Theorem 1.6: scaling properties of leaf measures under $\sigma^{\pm 1}$.
- §1.8, Theorem 1.15: scaling properties of leaf measures under holonomies (sliding between stable leaves along unstable leaves and *vice versa*). (These require certain conditions on a family of rectangles, which are satisfied if all rectangles in the family are open and the potential has the Walters property (Proposition 1.9), or for an arbitrary family of rectangles if the potential is constant (Proposition 1.10).)
- §1.9, Theorems 1.17, 1.18, and 1.19: construction of a product measure λ , an invariant measure μ with local product structure, and conditions for μ to give an equilibrium measure.
- §1.10, Theorem 1.20: Gibbs-type estimates for $m_x^s, m_x^u, \lambda, \mu$.

1.2. *Description of setting.* Let A be a finite set (the *alphabet*), and equip the set $A^{\mathbb{Z}}$ of all bi-infinite sequences over A with the metric $d(x, y) = 2^{-\min\{|n|: x_n \neq y_n\}}$. The *shift map* $\sigma: A^{\mathbb{Z}} \rightarrow A^{\mathbb{Z}}$ is defined by $(\sigma x)_n = x_{n+1}$. A (*two-sided*) *shift space* is a closed σ -invariant set $X \subset A^{\mathbb{Z}}$. Given such a shift space X , we will study the thermodynamic formalism of the homeomorphism $\sigma: X \rightarrow X$ equipped with a continuous *potential function* $\varphi: X \rightarrow \mathbb{R}$. To describe this, we first need some more terminology and notation.

A *word* over A is a finite string of symbols $w \in A^n$ for some n ; we write $|w| = n$ for the *length* of w . (The case $n = 0$ gives the *empty word*.) Given $x \in A^{\mathbb{Z}}$ and $i, j \in \mathbb{Z}$, we write $x_{[i,j]}$ for the word $x_i x_{i+1} \cdots x_{j-1}$, and similarly for $(i, j]$, $[i, j)$, and $[i, j]$. Given a shift space X and a word $w \in A^n$, the (*forward*) *cylinder* of w is

$$[w]^+ := \{x \in X : x_{[0,n]} = w\},$$

and the *language* of X is

$$\mathcal{L} := \bigcup_{n=0}^{\infty} \mathcal{L}_n \quad \text{where } \mathcal{L}_n := \{w \in A^n : [w]^+ \neq \emptyset\}.$$

Given a potential function $\varphi: X \rightarrow \mathbb{R}$, we assign a weight to each word $w \in \mathcal{L}$ by

$$\Phi(w) := \sup_{x \in [w]^+} S_n \varphi(x) \quad \text{where } S_n \varphi(x) := \sum_{k=0}^{n-1} \varphi(\sigma^k x). \tag{1.1}$$

The *n*th *partition sum* associated to (X, σ, φ) is

$$\Lambda_n := \sum_{w \in \mathcal{L}_n} e^{\Phi(w)}. \tag{1.2}$$

Given $m, n \in \mathbb{N}$, one quickly sees that

$$\Lambda_{m+n} = \sum_{u \in \mathcal{L}_m} \sum_{\substack{v \in \mathcal{L}_n \\ uv \in \mathcal{L}_{m+n}}} e^{\Phi(uv)} \leq \sum_{u \in \mathcal{L}_m} \sum_{\substack{v \in \mathcal{L}_n \\ uv \in \mathcal{L}_{m+n}}} e^{\Phi(u) + \Phi(v)} \leq \Lambda_m \Lambda_n, \tag{1.3}$$

and so Fekete's lemma guarantees that the following limit exists:

$$P := \lim_{n \rightarrow \infty} \frac{1}{n} \log \Lambda_n. \quad (1.4)$$

The number $P = P(X, \sigma, \varphi)$ is the *topological pressure*. Writing $M_\sigma(X)$ for the space of σ -invariant Borel probability measures on X , and $h: M_\sigma(X) \rightarrow [0, \infty)$ for the measure-theoretic entropy function, the variational principle [Wal82, Theorem 9.10] states that

$$P = \sup_{\mu \in M_\sigma(X)} \left(h(\mu) + \int \varphi d\mu \right).$$

A measure achieving this supremum is an *equilibrium measure*. There is always at least one equilibrium measure because the entropy function is upper semi-continuous.

1.3. Local product structure. We will be concerned with the structure and properties of equilibrium measures, and in particular with their product structure in terms of stable and unstable sets.

Given a shift space X , we say that $R \subset X$ has *product structure* (or is a *rectangle*) if for every $x, y \in R$, the *bracket* $[x, y]$ given by

$$[x, y]_n := \begin{cases} x_n, & n \leq 0, \\ y_n, & n \geq 0, \end{cases} \quad (1.5)$$

is defined (which requires $x_0 = y_0$) and lies in R . In this case, we fix $q \in R$ and consider the sets

$$\begin{aligned} W_R^u(q) &:= \{x \in R : x_n = q_n \text{ for all } n \leq 0\}, \\ W_R^s(q) &:= \{x \in R : x_n = q_n \text{ for all } n \geq 0\}, \end{aligned} \quad (1.6)$$

and then consider the bijection

$$\begin{aligned} \iota_q : W_R^u(q) \times W_R^s(q) &\rightarrow R, \\ (x, y) &\mapsto [y, x]. \end{aligned} \quad (1.7)$$

We say that a measure m on R is a *product measure* if $m = (\iota_q)_*(m_q^u \times m_q^s)$ for some measures m_q^u on $W_R^u(q)$ and m_q^s on $W_R^s(q)$.

Definition 1.2. A probability measure μ on X has *local product structure* if there exist a sequence of product measures m_n on rectangles R_n such that we have:

- $\mu|_{R_n} \ll m_n$ for every $n \in \mathbb{N}$; and
- $\mu(\bigcup_{n \in \mathbb{N}} R_n) = 1$.

1.4. Classes of shift spaces and potentials. To go beyond mere existence and deduce uniqueness, local product structure, or other stronger properties for equilibrium measures, one needs to know more about the shift space X and the potential φ . We gather some basic definitions and facts here.

- The *n th variation* of φ is $V_n(\varphi) := \sup\{|\varphi(x) - \varphi(y)| : x_{(-n,n)} = y_{(-n,n)}\}$.
- Every continuous $\varphi: X \rightarrow \mathbb{R}$ is uniformly continuous: $V_n(\varphi) \rightarrow 0$ as $n \rightarrow \infty$.

- φ is Hölder continuous if $V_n(\varphi)$ decays exponentially fast: there are $C, \alpha > 0$ such that $V_n(\varphi) \leq Ce^{-\alpha n}$ for all $n \in \mathbb{N}$.
- φ is Dini continuous (or has summable variations) if $\sum_n V_n(\varphi) < \infty$.
- φ has the Bowen property if there is $C > 0$ such that for every $n \in \mathbb{N}$ and every $x, y \in X$ with $x_{[0,n]} = y_{[0,n]}$, we have $|S_n\varphi(x) - S_n\varphi(y)| \leq C$.
- φ has the Walters property if for every $\epsilon > 0$, there is $k \in \mathbb{N}$ such that for all $n \in \mathbb{N}$ and $x, y \in X$ with $x_{[-k,n+k]} = y_{[-k,n+k]}$, we have $|S_n\varphi(x) - S_n\varphi(y)| \leq \epsilon$.

These properties have the following relationships:

$$\text{Hölder} \Rightarrow \text{Dini} \Rightarrow \text{Walters} \Rightarrow \text{Bowen}.$$

The Bowen property has the following immediate consequence:

$$\Phi(v) + \Phi(w) - C \leq \Phi(vw) \leq \Phi(v) + \Phi(w) \quad \text{for all } v, w \in \mathcal{L} \text{ with } vw \in \mathcal{L}. \quad (1.8)$$

A shift space $X \subset A^{\mathbb{Z}}$ is an SFT if there is a finite set of forbidden words $\mathcal{F} \subset A^* := \bigcup_{n=0}^{\infty} A^n$ such that

$$X = \{x \in A^{\mathbb{Z}} : x_{[i,j]} \notin \mathcal{F} \text{ for all } i, j \in \mathbb{Z}\}. \quad (1.9)$$

Every topologically mixing SFT has the following specification property: there is $t \in \mathbb{N}$ such that for all $v, w \in \mathcal{L}$, there is $u \in \mathcal{L}_t$ such that $vuw \in \mathcal{L}$. As mentioned in Remark 1.1, the following facts were already known.

- If X has specification and φ has the Bowen property, then there is a unique equilibrium measure [Bow75] and it has the K property [Led77, Cal22].
- If X is a mixing SFT and φ has the Walters property, then the unique equilibrium measure has local product structure and the Bernoulli property; see [Bow08, Hay94, Lep00] for Hölder continuous φ and [Wal78] for the extension to the Walters property.
- If X has specification and φ is Hölder continuous, then the unique equilibrium measure has local product structure and the Bernoulli property [Cli18].

Theorem A extends the ‘local product structure’ result in the last item to the case when φ has the Walters property. We do not address the question of whether the unique equilibrium measure is Bernoulli in this setting.

In the classical results above, an important role is played by the fact that the partition sums in equation (1.2) admit uniform counting bounds $e^{nP} \leq \Lambda_n \leq Qe^{nP}$, where $Q < \infty$ is independent of n , as well as by the existence of ‘large’ sets with product structure. An important feature of our approach is that our general results rely only on these rather flexible assumptions, rather than more restrictive assumptions on the structure of X .

1.5. *Construction of the leaf measures.* The definition of topological pressure in equation (1.4) gave it as an exponential growth rate, analogous to box (capacity) dimension. In dimension theory, one can also study Hausdorff dimension, which is a critical value rather than a growth rate; more precisely, one defines a one-parameter family of Hausdorff measures, whose total weight jumps from ∞ to 0 at a particular value of the parameter. This value is the Hausdorff dimension; Pesin and Pitskel’ [PP84] gave an analogous definition of topological pressure, building on an earlier work of Bowen [Bow73] for topological entropy.

In the symbolic setting, this definition goes as follows. Given $N \in \mathbb{N}$, let $\mathcal{L}_{\geq N} = \{w \in \mathcal{L} : |w| \geq N\}$ denote the set of words of length at least N , and given $Z \subset X$, consider the following set of covers of Z by cylinders corresponding to such words:

$$\mathbb{E}^+(Z, N) := \left\{ \mathcal{E} \subset \mathcal{L}_{\geq N} : Z \subset \bigcup_{w \in \mathcal{E}} [w]^+ \right\}. \quad (1.10)$$

Then to each $\alpha \in \mathbb{R}$, associate an outer measure m_α on X defined by

$$m_\alpha(Z) = \lim_{N \rightarrow \infty} \inf \left\{ \sum_{w \in \mathcal{E}} e^{\Phi(w) - |w|\alpha} : \mathcal{E} \subset \mathbb{E}^+(Z, N) \right\}. \quad (1.11)$$

The topological pressure $P \in \mathbb{R}$ is the unique real number with the property that $m_\alpha(X) = \infty$ for all $\alpha < P$, and $m_\alpha(X) = 0$ for all $\alpha > P$. Now one may naturally ask whether m_P has anything to do with the equilibrium measure(s) of (X, σ, φ) . There are two problems that arise immediately:

- (1) *a priori*, we could have $m_P(X) = 0$ or $m_P(X) = \infty$;
- (2) the outer measure m_P does not restrict to a Borel measure unless $m_P \equiv 0$. Indeed, if we consider for each $x \in X$ the *local unstable set* (or *leaf*)

$$W_{\text{loc}}^u(x) = \{y \in X : y_k = x_k \text{ for all } k \leq 0\},$$

then $\mathbb{E}^+(W_{\text{loc}}^u(x), N) = \mathbb{E}^+([x_0]^+, N)$ for all N if X is a subshift of finite type, and $m_P(W_{\text{loc}}^u(x)) = m_P([x_0]^+)$, from which one can quickly deduce that m_P is not additive on the Borel σ -algebra.

The first problem is addressed in §1.6. For now, we address the second problem, by defining a measure not on all of X , but on a local unstable set. We modify the definition in equation (1.11) slightly: instead of using weights $\Phi(w)$, we fix $x \in X$ and consider for each $w \in \mathcal{L}$ the quantity

$$\Phi_x^+(w) = \sup\{S_{|w|}\varphi(y) : y \in W_{\text{loc}}^u(x) \cap [w]^+\}. \quad (1.12)$$

(If $W_{\text{loc}}^u(x) \cap [w]^+ = \emptyset$, then $\Phi_x^+(w) = -\infty$ and $e^{\Phi_x^+(w)} = 0$.) Then define the unstable leaf measure as

$$m_x^u(Z) = \lim_{N \rightarrow \infty} \inf \left\{ \sum_{w \in \mathcal{E}} e^{\Phi_x^+(w) - |w|P} : \mathcal{E} \in \mathbb{E}^+(Z, N) \right\}. \quad (1.13)$$

Given $w \in \mathcal{L}_{\geq N}$, the set $W_{\text{loc}}^u(x) \cap [w]^+$ has diameter $\leq 2^{-N}$, which goes to 0 as $N \rightarrow \infty$, and thus [Cli24, Lemma 2.14] implies that m_x^u defines a Borel measure on $W_{\text{loc}}^u(x)$.

By reversing the direction of everything, we can analogously define a Borel measure m_x^s on the *local stable set* (or *leaf*)

$$W_{\text{loc}}^s(x) = \{y \in X : y_k = x_k \text{ for all } k \geq 0\}.$$

For the definition of m_x^s , we work with the backwards cylinders corresponding to words $w \in A^n$:

$$[w]^- = \{x \in X : x_{(-n,0]} = w\}.$$

Given $Z \subset W_{\text{loc}}^s(x)$ and $N \in \mathbb{N}$, we consider the collection of covers

$$\mathbb{E}^-(Z, N) = \left\{ \mathcal{E} \subset \mathcal{L}_{\geq N} : Z \subset \bigcup_{w \in \mathcal{E}} [w]^- \right\}. \tag{1.14}$$

Using the weight function

$$\Phi_x^-(w) = \sup \left\{ \sum_{k=0}^{|w|-1} \varphi(\sigma^{-k}y) : y \in W_{\text{loc}}^s(x) \cap [w]^- \right\}, \tag{1.15}$$

we define the leaf measure m_x^s by

$$m_x^s(Z) = \lim_{N \rightarrow \infty} \inf \left\{ \sum_{w \in \mathcal{E}} e^{\Phi_x^-(w) - |w|P} : \mathcal{E} \in \mathbb{E}^-(Z, N) \right\}. \tag{1.16}$$

Once again, [Cll24, Lemma 2.14] guarantees that m_x^s is a Borel measure on $W_{\text{loc}}^s(x)$. Now we must provide some way of guaranteeing that the leaf measures m_x^u and m_x^s are positive and finite; we will do this in the next section. We conclude this section by observing that the set $W_{\text{loc}}^u(x)$ and the measure m_x^u only depend on $x_{(-\infty, 0]}$; similarly, $W_{\text{loc}}^s(x)$ and m_x^s depend only on $x_{[0, \infty)}$. This is immediate from the definitions but deserves to be recorded.

PROPOSITION 1.3. *If $x_{(-\infty, 0]} = y_{(-\infty, 0]}$, then $W_{\text{loc}}^u(x) = W_{\text{loc}}^u(y)$ and $m_x^u = m_y^u$. If $x_{[0, \infty)} = y_{[0, \infty)}$, then $W_{\text{loc}}^s(x) = W_{\text{loc}}^s(y)$ and $m_x^s = m_y^s$.*

Remark 1.4. We will occasionally abuse notation slightly by using the notation $W_{\text{loc}}^u(x)$, m_x^u when $x = \dots x_{-2}x_{-1}x_0$ is a backward-infinite sequence, and $W_{\text{loc}}^s(x)$, m_x^s when $x = x_0x_1x_2 \dots$ is forward-infinite. By Proposition 1.3, the meaning of this notation is well defined by extending such an x to any bi-infinite sequence in X .

1.6. *Conditions for finiteness.* As the arguments in [CPZ19] reveal, the key property needed to guarantee positivity and finiteness of the leaf measures is uniform control of various versions of the partition sums Λ_n from equation (1.2). Start by observing that equation (1.4) means that $\Lambda_n \approx e^{nP}$ for large n , but leaves open the possibility that $\Lambda_n e^{-nP}$ can approach 0 or ∞ subexponentially. In fact, by Fekete’s lemma, the submultiplicativity property $\Lambda_{m+n} \leq \Lambda_m \Lambda_n$ guarantees that

$$\Lambda_n \geq e^{nP} \quad \text{for all } n; \tag{1.17}$$

however, there is no universal upper bound. We define

$$\overline{Q} := \overline{\lim}_{n \rightarrow \infty} \Lambda_n e^{-nP} \in [1, \infty]. \tag{1.18}$$

To obtain good bounds on m_x^u , we will need $\overline{Q} < \infty$. This is known to be true for transitive SFTs with Hölder continuous potentials, and in many other settings as well; see for example §2 and [CT13, Proposition 5.3]. We will also need good control of partition sums restricted to $W_{\text{loc}}^u(x)$: let

$$\Lambda_n^+(x) := \sum_{w \in \mathcal{L}_n} e^{\Phi_x^+(w)}, \tag{1.19}$$

recalling that words with $W_{\text{loc}}^u(x) \cap [w]^+ = \emptyset$ make no contribution to the sum, and then define

$$\overline{Q}_x^+ := \overline{\lim}_{n \rightarrow \infty} \Lambda_n^+(x)e^{-nP}, \quad \underline{Q}_x^+ := \underline{\lim}_{n \rightarrow \infty} \Lambda_n^+(x)e^{-nP}. \tag{1.20}$$

Clearly, we have $\underline{Q}_x^+ \leq \overline{Q}_x^+ \leq \overline{Q}$, but we have no *a priori* lower bound on \underline{Q}_x^+ . Replacing $+$ with $-$ in equations (1.19) and (1.20) yields analogous quantities $\underline{Q}_x^- \leq \overline{Q}_x^- \leq \overline{Q}$. The following result is proved in §3.

THEOREM 1.5. *Let X be a two-sided shift space on a finite alphabet with language \mathcal{L} , and $\varphi: X \rightarrow \mathbb{R}$ a continuous potential. For each $x \in X$, define a Borel measure m_x^u on $W_{\text{loc}}^u(x)$ by equation (1.13) and a Borel measure m_x^s on $W_{\text{loc}}^s(x)$ by equation (1.16). Then we have*

$$\overline{Q}_x^+ / \overline{Q} \leq m_x^u(W_{\text{loc}}^u(x)) \leq \underline{Q}_x^+, \tag{1.21}$$

$$\overline{Q}_x^- / \overline{Q} \leq m_x^s(W_{\text{loc}}^s(x)) \leq \underline{Q}_x^-. \tag{1.22}$$

Theorem 1.5 guarantees that the measures m_x^u and m_x^s are finite as soon as $\overline{Q} < \infty$, but leaves open the possibility that they may vanish for some x . For a shift with specification and a potential with the Bowen property, there is $c > 0$ such that $\underline{Q}_x^\pm \geq c$ for all $x \in X$ [Bow75], so that, in particular, all leaf measures are non-zero. See §2 for a more general statement.

1.7. Scaling under dynamics. A crucial property of α -dimensional Hausdorff measure is the way it transforms under geometric scaling: if two sets are related by a transformation that scales distances by a factor of r , then their Hausdorff measures are related by a factor of r^α . The corresponding property for the measures m_x^u and m_x^s concerns how they transform under the dynamics of σ ; they scale by a factor of $e^{P-\varphi}$, as described in the following result, which is proved in §4.

THEOREM 1.6. *Let X be a two-sided shift space on a finite alphabet with language \mathcal{L} , and $\varphi: X \rightarrow \mathbb{R}$ a continuous potential. Let m_x^u and m_x^s be the families of leaf measures defined by equations (1.13) and (1.16). Then if $Z \subset W_{\text{loc}}^u(x)$ is a Borel set such that $\sigma(Z) \subset W_{\text{loc}}^u(\sigma x)$, we have*

$$m_{\sigma x}^u(\sigma Z) = \int_Z e^{-\varphi(y)+P} dm_x^u(y). \tag{1.23}$$

Similarly, given a Borel set $Z \subset W_{\text{loc}}^s(x)$, we have

$$m_{\sigma^{-1}x}^s(\sigma^{-1}Z) = \int_Z e^{-\varphi(y)+P} dm_x^s(y). \tag{1.24}$$

Remark 1.7. It is occasionally useful to write the scaling property in equation (1.23) in one of the following equivalent forms, valid whenever $\sigma y \in W_{\text{loc}}^u(\sigma x)$ (that is, $Y_{(-\infty,1]} = X_{(-\infty,1]}$):

$$\frac{dm_{\sigma x}^u}{d(\sigma_* m_x^u)}(\sigma y) = e^{-\varphi(y)+P} \quad \text{or} \quad \frac{dm_x^u}{d(\sigma^* m_{\sigma x}^u)}(y) = e^{\varphi(\sigma^{-1}y)-P}. \tag{1.25}$$

If $y_{(-\infty, n]} = x_{(-\infty, n]}$, then iterating the second of these gives

$$\frac{dm_x^u}{d((\sigma^n)_* m_{\sigma^n x}^u)}(y) = e^{\sum_{k=1}^n \varphi(\sigma^{-k}y) - nP}. \tag{1.26}$$

Analogous formulas hold for m_x^s . In particular,

$$\frac{dm_{\sigma^{-n}x}^s}{d((\sigma^n)_* m_x^s)}(y) = e^{-\sum_{k=0}^{n-1} \varphi(\sigma^{-k}y) + nP}. \tag{1.27}$$

In §1.10, we will use these scaling properties to obtain Gibbs-type estimates.

1.8. *Scaling under holonomies.* Recalling §1.3, we say $R \subset X$ has *product structure* and refer to R as a *rectangle* if for every $x, y \in R$, the bracket $[x, y]$ from equation (1.5) is defined and lies in R . Note that every rectangle must be contained in a 1-cylinder: if R is a rectangle, then there is $a \in A$ such that $R \subset [a]^+ = [a]^-$.

Given a rectangle R and a point $x \in R$, we will write (see equation (1.6))

$$W_R^u(x) := W_{\text{loc}}^u(x) \cap R \quad \text{and} \quad W_R^s(x) := W_{\text{loc}}^s(x) \cap R.$$

Given $z, y \in R$, the (stable) *holonomy map* $\pi_{z,y}^s : W_R^u(z) \rightarrow W_R^u(y)$ is defined by

$$\pi_{z,y}^s(x) = [y, x], \tag{1.28}$$

so that $\{\pi_{z,y}^s(x)\} = W_{\text{loc}}^s(x) \cap W_{\text{loc}}^u(y)$; the map $\pi_{z,y}^s$ ‘slides’ a point x along its stable leaf until it reaches $W_{\text{loc}}^u(y)$. We will be interested in rectangles on which the unstable leaf measures m_x^u transform nicely under holonomies.

Definition 1.8. Given a collection \mathcal{R} of rectangles, the family of unstable leaf measures has *uniformly continuous holonomies* on \mathcal{R} if for every $\epsilon > 0$, there exists $\delta > 0$ such that given any $R \in \mathcal{R}$ and $y, z \in R$ such that $d(y, z) < \delta$, we have $m_y^u(Y) = e^{\pm\epsilon} m_z^u(\pi_{y,z}^s(Y))$ for all measurable $Y \subset W_R^u(y)$. (We use the notation $A = e^{\pm C} B$ to mean that $e^{-C} B \leq A \leq e^C B$.)

We prove the following in §5.

PROPOSITION 1.9. *If φ has the Walters property, then the leaf measures m_x^u have uniformly continuous holonomies on the family of open rectangles.*

PROPOSITION 1.10. *If $\varphi \equiv 0$, then the leaf measures m_x^u have uniformly continuous holonomies on the family of all rectangles.*

Remark 1.11. A shift space has open rectangles if and only if it has a synchronizing word. For such shift spaces, Proposition 1.9 allows us to study equilibrium measures for a broad class of potential functions. However, there are many shift spaces, such as the natural coding space for Sinai billiards [BD20, CD24], in which we should not expect to find any open rectangles, and thus Proposition 1.9 cannot be used, but Proposition 1.10 can still provide information about the measure of maximal entropy. We expect that

the definition of the leaf measures could be modified to guarantee uniformly continuous holonomies on the family of all rectangles for a broader class of potentials, but we do not pursue this here.

In the next section, it will be important to have a formula for the Radon–Nikodym derivative of the holonomy map. To give this, we start with the following direct consequence of equation (1.5):

$$\text{if } x_{[0,n]} = y_{[0,n]} \quad \text{then } [\sigma^n x, \sigma^n y] = \sigma^n[x, y]. \tag{1.29}$$

With equation (1.29) in mind, the following is immediate.

LEMMA 1.12. *Given any rectangle R , any $n \in \mathbb{N}$, and any $w \in \mathcal{L}_{n+1}$, the sets $\sigma^n(R \cap [w]^+) = \sigma^n(R) \cap [w]^-$ and $\sigma^{-n}(R \cap [w]^-) = \sigma^{-n}(R) \cap [w]^+$ are rectangles as well. (They may be empty.)*

Definition 1.13. A family \mathcal{R} of rectangles is \mathcal{L} -invariant if given any $R \in \mathcal{R}$, $n \in \mathbb{N}$, and $w \in \mathcal{L}_{n+1}$, the rectangles $\sigma^n(R \cap [w]^+)$ and $\sigma^{-n}(R \cap [w]^-)$ are contained in \mathcal{R} .

The families of rectangles in Propositions 1.9 and 1.10 are both \mathcal{L} -invariant.

Definition 1.14. The family of leaf measures m_x^u is positive on a family \mathcal{R} of rectangles if for every $R \in \mathcal{R}$, there exists $x \in R$ such that $m_x^u(W_R^u(x)) > 0$.

THEOREM 1.15. *Let \mathcal{R} be an \mathcal{L} -invariant family of rectangles and suppose that the family of leaf measures m_x^u is positive on \mathcal{R} . Then the following are equivalent.*

- (1) *The leaf measures m_x^u have uniformly continuous holonomies on \mathcal{R} .*
- (2) *The sum*

$$\Delta^s(x', x) := \sum_{n=0}^{\infty} \varphi(\sigma^n x') - \varphi(\sigma^n x) \tag{1.30}$$

converges uniformly on $\{(x, x') \in R^2 : R \in \mathcal{R}, x' \in W_R^s(x)\}$, is uniformly bounded on this set, and for every $R \in \mathcal{R}$ and $y, z \in R$, we have

$$\frac{d(\pi_{z,y}^s)_* m_z^u}{dm_y^u}(x) = e^{\Delta^s((\pi_{z,y}^s)^{-1}(x), x)}. \tag{1.31}$$

The proof for this result is in §5. An analogous result is true if we reverse the roles of stable and unstable, and change the sign of each instance of n .

Remark 1.16. It is worth observing that equation (1.31) gives

$$m_z^u(W_R^u(z)) = m_z^u((\pi_{z,y}^s)^{-1}(W_R^u(y))) = \int_{W_R^u(y)} e^{\Delta^s((\pi_{z,y}^s)^{-1}(x), x)} dm_y^u(x).$$

Thus, if the conditions of Theorem 1.15 are satisfied, we actually have a stronger version of positivity: $m_y^u(W_R^u(y)) > 0$ for every $y \in R \in \mathcal{R}$.

1.9. *Product measure construction of an equilibrium measure.* To go from the leaf measures m_x^u and m_x^s to an equilibrium measure for (X, σ, φ) , we start with a product construction. Suppose that \mathcal{R} is an \mathcal{L} -invariant family of rectangles on which the families of leaf measures m_x^u and m_x^s both have uniformly continuous holonomies and are positive in the sense of Definition 1.14.

Given $R \in \mathcal{R}$ and $q \in R$, consider the bijection $\iota_q: W_R^u(q) \times W_R^s(q) \rightarrow R$ from equation (1.7), defined by $\iota_q(x, y) = [y, x]$, and the product measure $m_{R,q} := (\iota_q)_*(m_q^u \times m_q^s)$, for which

$$m_{R,q}(Z) = \int_{W_R^u(q)} \int_{W_R^s(q)} \mathbf{1}_Z([y, z]) dm_q^s(y) dm_q^u(z). \tag{1.32}$$

Let $\lambda_R \ll m_{R,q}$ be the measure on R defined by

$$\frac{d\lambda_R}{dm_{R,q}}(z) = e^{\Delta^u([y,z],y)} e^{\Delta^s([y,z],y)}. \tag{1.33}$$

The following is proved in §6 and justifies the suppression of q in the notation λ_R .

THEOREM 1.17. *Let X be a two-sided shift space and $\varphi: X \rightarrow \mathbb{R}$ be continuous. Suppose that \mathcal{R} is an \mathcal{L} -invariant family of rectangles on which the families of leaf measures m_x^u and m_x^s both have uniformly continuous holonomies and are positive. Then for every $R \in \mathcal{R}$, the measure λ_R defined in equations (1.32) and (1.33) is independent of the choice of $q \in R$, and is non-zero.*

Given disjoint $R_1, \dots, R_\ell \in \mathcal{R}$, define a measure λ_R on the union $R = \bigcup_{i=1}^\ell R_i$ by

$$\lambda_R = \sum_{i=1}^\ell \lambda_{R_i}. \tag{1.34}$$

The first return time function $\tau: R \rightarrow \mathbb{N} \cup \{\infty\}$ is given by

$$\tau(x) = \min\{n \geq 1 : \sigma^n(x) \in R\}.$$

If $\lambda_R(\{x \in R : \tau(x) = \infty\}) = 0$, then the first return map $T: R \rightarrow R$ given by $T(x) = \sigma^{\tau(x)}(x)$ is defined by λ_R -almost everywhere. In §6, we prove the following.

THEOREM 1.18. *Let X, φ, \mathcal{R} be as in Theorem 1.17, and R, τ, T as above. If $\lambda_R(\{x \in R : \tau(x) = \infty\}) = 0$, then λ_R is T -invariant.*

The procedure for passing from a T -invariant measure on R to a σ -invariant measure on X is standard: under the hypotheses of Theorem 1.18, write $Y_n := \{y \in R : \tau(y) > n\}$ and consider the measure

$$\mu := \sum_{n=0}^\infty \sigma_*^n \lambda_R|_{Y_n}. \tag{1.35}$$

Clearly, $\mu|_R = \lambda_R$. In §6, we prove the following result.

THEOREM 1.19. *Let $X, \varphi, \mathcal{R}, R, \tau, T$ be as in Theorems 1.17 and 1.18. Suppose that λ_R is positive, that $\int \tau d\lambda_R < \infty$, and that $\overline{Q} < \infty$. Then the measure μ defined in equation (1.35) is positive, finite, and σ -invariant; moreover, its normalization $\mu/\mu(X)$ is an equilibrium measure with local product structure.*

1.10. Gibbs-type estimates. We conclude our general results with a description of how combining Theorem 1.5 with the scaling estimates in equation (1.26) provides Gibbs-type estimates on the weight that the leaf measures give cylinders. These lead in turn to Gibbs-type bounds for the measures λ_R from equations (1.32) and (1.33).

Given $x \in X$ and $w \in \mathcal{L}_n$ such that $w_1 = x_0$, we adopt the notation

$$x.w := \cdots x_{-2}x_{-1}w_1w_2w_3 \cdots w_n. \tag{1.36}$$

That is, $x.w$ is the left-infinite sequence obtained by taking the negative half of x and appending w . (The result may or may not be legal in X : it is legal if and only if $W_{\text{loc}}^u(x) \cap [w]^+ \neq \emptyset$.) The sequence $x.w$ is indexed by $(-\infty, 0] \cap \mathbb{Z}$, so $(x.w)_0 = w_n$, $(x.w)_{-1} = w_{n-1}$, and so on. Now observe that for a symbol a in the alphabet A ,

$$\sigma^n(W_{\text{loc}}^u(x) \cap [w]^+) = \bigcup_{a \in A} W_{\text{loc}}^u(x.wa),$$

where, as in Remark 1.4, we abuse notation slightly by using the notation W_{loc}^u when $x.wa$ is only a one-sided infinite sequence; this is justified by Proposition 1.3. Some of the sets $W_{\text{loc}}^u(x.wa)$ may be empty.

Consider the quantity

$$V_x^+(w) := \sup\{|S_n\varphi(y) - S_n\varphi(z)| : y, z \in W_{\text{loc}}^u(x) \cap [w]^+\}. \tag{1.37}$$

We see immediately that given any $y \in W_{\text{loc}}^u(x) \cap [w]^+$, we have

$$\Phi_x^+(w) - V_x^+(w) \leq S_n\varphi(y) \leq \Phi_x^+(w). \tag{1.38}$$

Given a single symbol $a \in A$ such that $W_{\text{loc}}^u(x.wa) \neq \emptyset$, write $m_{x.wa}^u$ for the corresponding leaf measure; then equations (1.26), (1.38), and Proposition 1.3 give

$$e^{\Phi_x^+(w) - nP - V_x^+(w)} \leq \frac{dm_x^u}{d((\sigma^*)^n m_{x.wa}^u)}(y) \leq e^{\Phi_x^+(w) - nP}$$

for each $y \in W_{\text{loc}}^u(x) \cap [wa]^+$. Writing $\|m_{x.wa}^u\| := m_{x.wa}(W_{\text{loc}}^u(x.wa))$ for the total weight of the measure $m_{x.wa}^u$, we obtain

$$e^{-V_x^+(w)} \sum_a \|m_{x.wa}^u\| \leq \frac{m_x^u([w]^+)}{e^{\Phi_x^+(w) - nP}} \leq \sum_a \|m_{x.wa}^u\|,$$

and Theorem 1.5 lets us conclude the following Gibbs-type estimate.

THEOREM 1.20. *Let X be a two-sided shift space on a finite alphabet A with language \mathcal{L} , and $\varphi : X \rightarrow \mathbb{R}$ a continuous potential. Then given any $x \in X$ and $w \in \mathcal{L}_n$, we have*

$$\frac{\sum_{a \in A} \overline{Q}_{x.wa}^+}{e^{V_x^+(w)} \overline{Q}} \leq \frac{m_x^u([w]^+)}{e^{\Phi_x^+(w) - nP}} \leq \sum_{a \in A} \underline{Q}_{x.wa}^+. \tag{1.39}$$

An analogous bound holds for $m_x^s([w]^-)$:

$$\frac{\sum_{a \in A} \overline{Q}_{aw.x}}{e^{V_x^-(w)} \underline{Q}} \leq \frac{m_x^s([w]^-)}{e^{\Phi_x^-(w) - nP}} \leq \sum_{a \in A} \underline{Q}_{aw.x}^- \tag{1.40}$$

Once again, we point out that if X has the specification property and φ has the Bowen property, then the quantities in equations (1.39) and (1.40) are all bounded away from 0 and ∞ independently of x and w , yielding the usual Gibbs property.

Theorem 1.20 yields an upper Gibbs bound for the product measures used in §1.9; the constant involved is given in terms of \underline{Q} , and so for this bound to be useful, we will need to know that $\underline{Q} < \infty$.

COROLLARY 1.21. *Let X be a two-sided shift space on a finite alphabet and $\varphi: X \rightarrow \mathbb{R}$ be continuous. Suppose that \mathcal{R} is an \mathcal{L} -invariant family of rectangles on which the families of leaf measures m_x^u and m_x^s both have uniformly continuous holonomies. Let $C = \max(\|\Delta^s\|, \|\Delta^u\|)$, which is finite by Theorem 1.15, and let $K = (\#A) \underline{Q}^2 e^{2C}$. Then for every $R \in \mathcal{R}$, the measure λ_R defined in equations (1.32) and (1.33) satisfies the following bound for all $w \in \mathcal{L}$:*

$$\lambda_R([w]^+) \leq K e^{\Phi(w) - |w|P}. \tag{1.41}$$

Proof. If $[w]^+ \cap R = \emptyset$, there is nothing to prove, so assume the intersection is non-empty. By Theorem 1.17, we can define λ_R using $q \in [w]^+ \cap R$. We get

$$\begin{aligned} \lambda_R([w]^+) &= \int_{W_R^u(q)} \int_{W_R^s(q)} e^{\Delta^u([y,z],y)} e^{\Delta^s([y,z],z)} \mathbf{1}_{[w]^+} dm_q^s(y) dm_q^u(z) \\ &\leq e^{2C} \int_{W_{loc}^u(q)} \int_{W_{loc}^s(q)} \mathbf{1}_{[w]^+} dm_q^s(y) dm_q^u(z) \\ &= e^{2C} \int_{W_{loc}^u(q) \cap [w]^+} \int_{W_{loc}^s(q)} dm_q^s(y) dm_q^u(z) \\ &= e^{2C} m_q^u([w]^+) m_q^s(W_{loc}^s(q)). \end{aligned}$$

By Theorems 1.5 and 1.20, we have

$$m_q^u([w]^+) m_q^s(W_{loc}^s(q)) \leq (\#A) \underline{Q}^2 e^{\Phi^+(w)},$$

which proves the corollary. □

2. Examples

2.1. *Subshifts of finite type.* Let X be a topologically mixing subshift of finite type on a finite alphabet A , determined by a finite set \mathcal{F} of forbidden words. Let $\varphi: X \rightarrow \mathbb{R}$ have the Walters property. Then it is well known [Bow75, Wal78] that (X, φ) has a unique equilibrium measure, and that $\overline{Q} < \infty$ and $\inf_x \underline{Q}^+ > 0$, $\inf_x \underline{Q}^- > 0$, so the leaf measures m_x^u and m_x^s are uniformly positive and finite by Theorem 1.5.

The product measure construction in §1.9 can be carried out as follows. Let $k = \max\{|u| : u \in \mathcal{F}\}$, and observe that for all $w \in \mathcal{L}$ with $|w| \geq k$, the cylinder $[w]^+$ has product structure: indeed, given any $x, y \in [w]^+$, any subword of $[x, y]$ with length

$\leq k$ must be a subword of either x or y , and thus cannot lie in \mathcal{F} (since $x, y \in X$), allowing us to conclude that $[x, y] \in X$ and hence $[x, y] \in [w]^+$.

By Proposition 1.9, the leaf measures m_x^u and m_x^s have uniformly continuous holonomies on the family \mathcal{R} of open rectangles. By the previous paragraph, this family contains $[w]^+$ for every $w \in \mathcal{L}_k$. So we can write X as the finite union of open rectangles:

$$X = \bigcup_{w \in \mathcal{L}_k} [w]^+.$$

On each $[w]^+$, equations (1.32) and (1.33) produce a positive and finite measure λ_w , and taking $R = X$, we have return time $\tau \equiv 1$, so the construction in equations (1.34) and (1.35) reduces to

$$\mu = \sum_{w \in \mathcal{L}_k} \lambda_w.$$

The return time is integrable (since it is bounded and each λ_w is finite), so by Theorem 1.19, $\mu/\mu(X)$ is the unique equilibrium measure.

2.2. *Synchronizing words.* The result for subshifts of finite type can be extended to shift spaces with a synchronizing word and the appropriate counting estimates.

Definition 2.1. A word v is said to be *synchronizing* if for every pair $u, w \in \mathcal{L}$ such that $uv, vw \in \mathcal{L}$, we have that $uvw \in \mathcal{L}$ as well.

Equivalently, v is synchronizing if the cylinder $[v]^+$ has product structure; in particular, X has a synchronizing word if and only if the family \mathcal{R} of open rectangles (as in Proposition 1.9) is non-empty. In this section, we give a condition for our main results to apply to such shift spaces. In a separate paper [CD24], we will study shift spaces that code dispersing billiards and do not have any open rectangles.

We remark that a shift space is a subshift of finite type if and only if all sufficiently long words are synchronizing. To go beyond SFTs, we impose a condition on sequences that do not contain a given synchronizing word: given a synchronizing word $v \in \mathcal{L}$ for a shift space X , we write

$$Y_v = \{x \in X : x \text{ does not contain } v\}. \tag{2.1}$$

Observe that Y_v is closed and shift-invariant.

THEOREM 2.2. *Let X be a shift space with a synchronizing word v . Suppose that $\varphi : X \rightarrow \mathbb{R}$ has the Walters property, and that the subshift Y_v defined in equation (2.1) satisfies*

$$P(Y_v, \varphi) < P(X, \varphi). \tag{2.2}$$

Then the following are true.

- (1) (X, σ, φ) has a unique equilibrium measure.
- (2) The equilibrium measure has local product structure in the sense of §1.3.

- (3) Writing $R = [v]^+$ and letting $\tau : R \rightarrow \mathbb{N} \cup \{\infty\}$ be the first return time, the measure $\lambda = \lambda_R$ defined by equations (1.32) and (1.33) is non-zero, and $\int \tau d\lambda < \infty$.
- (4) The σ -invariant measure μ defined in equation (1.35) is a scalar multiple of the unique equilibrium measure.
- (5) There exists $K > 0$ such that if $w \in \mathcal{L}$ begins and ends with the synchronizing word v , then

$$K^{-1} e^{-|w|P(X,\varphi)+\Phi(w)} \leq \mu([w]^+) \leq K e^{-|w|P(X,\varphi)+\Phi(w)}. \tag{2.3}$$

Remark 2.3. To deduce Theorem A from Theorem 2.2, it suffices to observe that if X is a shift space with the specification property, then it has a synchronizing word [Ber88], and equation (2.2) holds for every potential with the Bowen property. This last assertion can be deduced using the fact that (X, φ) has a unique equilibrium measure μ , and that μ is fully supported [Bow75], so that, in particular, $\mu([v]^+) > 0$ and therefore $\mu(Y_v) = 0$. By upper semi-continuity of entropy, (Y_v, φ) has an equilibrium measure $\nu \neq \mu$, for which $P(Y_v, \varphi) = h(\nu) + \int \varphi d\nu < P(X, \varphi)$.

The remainder of this section is devoted to the proof of Theorem 2.2, which will proceed along the following lines.

Step 1. Use the synchronizing property together with equation (2.2) to prove that the set $\mathcal{G} \subset \mathcal{L}$ of words that start and end with v has the specification property.

Step 2. Use this specification property and equation (2.2) to apply results from [CT13, PYY22], deducing uniqueness and uniform counting bounds on partition sums.

Step 3. Use these counting bounds together with Theorem 1.5 to obtain lower bounds on m_x^u and m_x^s whenever $x \in [v]^+$, and thus deduce that $\lambda([v]^+) > 0$.

Step 4. Use equation (2.2) and the Gibbs bounds from §1.10 to show that $\int \tau d\lambda < \infty$ and to deduce the Gibbs bounds in equation (2.3) for every $w \in \mathcal{G}$.

Step 5. Apply Theorem 1.19 to deduce that $\mu/\mu(X)$ is an equilibrium measure.

Before carrying these out, we set up some notation and recall a lemma. Recalling the notation $\Lambda_n = \sum_{|w|=n} e^{\Phi(w)}$ from (1.2), given $\mathcal{D} \subset \mathcal{L}$, we write

$$\Lambda_n(\mathcal{D}) = \sum_{w \in \mathcal{D}_n} e^{\Phi(w)} \quad \text{and} \quad Q_n(\mathcal{D}) = \Lambda_n(\mathcal{D})e^{-nP(X,\varphi)}.$$

A collection $\mathcal{D} \subset \mathcal{L}$ is called *factorial* if it is closed under passing to subwords. The subshift associated to a factorial collection \mathcal{D} is

$$X_{\mathcal{D}} := \{x \in X : \text{every subword of } x \text{ is in } \mathcal{D}\}.$$

LEMMA 2.4. *If \mathcal{D} is factorial and φ is continuous, then $(1/n) \log \Lambda_n(\mathcal{D}) \rightarrow P(X_{\mathcal{D}}, \varphi)$.*

Proof. For $\varphi = 0$, this is [CP19, Lemma 2.7]; the proof in §4.4 of that paper extends to arbitrary continuous φ with routine modifications; see Appendix A. □

We will apply Lemma 2.4 to the factorial collection

$$\mathcal{B} := \{w \in \mathcal{L} : w \text{ does not contain } v\},$$

for which we have $X_{\mathcal{B}} = Y_v$, so that the condition $P(Y_v, \varphi) < P(X, \varphi)$ together with Lemma 2.4 guarantees that

$$\lim_{n \rightarrow \infty} \frac{1}{n} \log \Lambda_n(\mathcal{B}) < P(X, \varphi). \tag{2.4}$$

We will often use the following consequence of this:

$$\sum_{n=1}^{\infty} Q_n(\mathcal{B}) = \sum_{n=1}^{\infty} \Lambda_n(\mathcal{B}) e^{-nP(X, \varphi)} < \infty. \tag{2.5}$$

With these preliminaries set up, we turn our attention to Step 1 of the proof of Theorem 2.2. We need the following lemma.

LEMMA 2.5. *If equation (2.5) holds, then there exists $u \in \mathcal{L}$ such that $vuv \in \mathcal{L}$.*

Proof. Let $\mathcal{D} = \mathcal{B} \cup ((\mathcal{B}v\mathcal{B}) \cap \mathcal{L})$ be the set of words in \mathcal{L} that do not contain two disjoint copies of v . Then we have

$$\Lambda_n(\mathcal{D}) \leq \Lambda_n(\mathcal{B}) + e^{\Phi(v)} \sum_{i=0}^{n-|v|} \Lambda_i(\mathcal{B}) \Lambda_{n-i-|v|}(\mathcal{B}). \tag{2.6}$$

Recall also from §1.6 that $\Lambda_n = \Lambda_n(\mathcal{L}) \geq e^{nP}$, so equation (2.6) gives

$$\frac{\Lambda_n(\mathcal{D})}{\Lambda_n(\mathcal{L})} \leq \Lambda_n(\mathcal{D}) e^{-nP} \leq Q_n(\mathcal{B}) + e^{\Phi(v)-|v|P} \sum_{i=0}^{n-|v|} Q_i(\mathcal{B}) Q_{n-|v|-i}(\mathcal{B}). \tag{2.7}$$

Writing $c_i = Q_i(\mathcal{B})$, observe that equation (2.5) gives

$$\sum_{\ell=0}^{\infty} \sum_{i=0}^{\ell} c_i c_{\ell-i} = \left(\sum_{k=0}^{\infty} c_k \right)^2 < \infty, \tag{2.8}$$

so $\sum_{i=0}^{\ell} c_i c_{\ell-i} \rightarrow 0$ as $\ell \rightarrow \infty$. Thus, the right-hand side of equation (2.7) converges to 0 as $n \rightarrow \infty$. For sufficiently large n , this gives $\Lambda_n(\mathcal{D}) < \Lambda_n(\mathcal{L})$, so $\mathcal{D} \neq \mathcal{L}$, which proves Lemma 2.5. □

PROPOSITION 2.6. *Writing $\mathcal{G} = \mathcal{L} \cap v\mathcal{L} \cap \mathcal{L}v$ for the set of words in \mathcal{L} that both start and end with v , the following are true whenever equation (2.5) holds.*

- $\mathcal{B}\mathcal{G}\mathcal{B}$ is a decomposition of the language \mathcal{L} : for every $w \in \mathcal{L}$, there are $u^p, u^s \in \mathcal{B}$ and $u^s \in \mathcal{G}$ such that $w = u^p u^s u^s$.
- \mathcal{G} has the specification property: there is $t \in \mathbb{N}$ such that for every $w, w' \in \mathcal{G}$, there is $u \in \mathcal{L}_t$ such that $wuw' \in \mathcal{G}$.

Proof. For the first claim, if w does not contain v , then we take $u^p = w$, and set u^s and u^s to be the empty word. If w does contain v , then we take u^p to be the initial segment of w

preceding the first appearance of v , we take u^s to be the final segment of w following the last appearance of v , and we take u^s to be the subword of w lying between u^p and u^s .

For the second claim, let $u \in \mathcal{L}$ be provided by Lemma 2.5 and let $t = |u|$. Then given any $w, w' \in \mathcal{G}$, we claim that $wuw' \in \mathcal{G}$. Indeed, by the definition of \mathcal{G} , we have $w = qv$ and $w' = vq'$ for some $q, q' \in \mathcal{L}$, and thus $wuw' = qvuvq'$. By the synchronizing property, since $qv \in \mathcal{L}$ and $vuv \in \mathcal{L}$, we deduce that $qvuv \in \mathcal{L}$, and since $vq' \in \mathcal{L}$, we apply the property again to get $wuw' = qvuvq' \in \mathcal{L}$. This word starts and ends with v since w and w' do, so it lies in \mathcal{G} . □

Now we are in a position to carry out Step 2, and obtain uniqueness and uniform counting bounds. These are provided by the following result.

THEOREM 2.7. *Suppose X is a shift space on a finite alphabet with language \mathcal{L} , and that $\varphi: X \rightarrow \mathbb{R}$ is continuous. Suppose moreover that there are $\mathcal{C}^p, \mathcal{G}, \mathcal{C}^s \subset \mathcal{L}$ such that the following conditions hold.*

- (I) *Specification on \mathcal{G} : there is $t \in \mathbb{N}$ such that for all $w^1, w^2, \dots, w^n \in \mathcal{G}$, there are $u^1, \dots, u^{n-1} \in \mathcal{L}_t$ such that $w^1u^1w^2u^2 \dots u^{n-1}w^n \in \mathcal{L}$.*
- (II) *Bowen property on \mathcal{G} : there is $C > 0$ such that for every $w \in \mathcal{G}$ and $x, y \in [w]$, we have $|S_{|w|}\varphi(x) - S_{|w|}\varphi(y)| \leq C$.*
- (III) *$\overline{\lim}_{n \rightarrow \infty} \log(\Lambda_n(\mathcal{C}^p \cup \mathcal{C}^s))/n < P(\varphi)$.*

Then X has a unique equilibrium measure, and $\overline{Q} < \infty$.

Proof. This is nearly the form of [CT13, Theorem C], except that there, the specification property is also required to hold for the sets $\mathcal{G}(M) = \{u^p w u^s \in \mathcal{L} : u^p \in \mathcal{C}^p, u^s \in \mathcal{C}^s, w \in \mathcal{G}, |u^{p,s}| \leq M\}$. An analogous result for flows was proved in [CT16], and was later improved by Pacifico, Yang, and Yang [PYY22], who showed that it suffices to have specification for \mathcal{G} itself. Their arguments can be readily adapted to the symbolic setting, see [Cli22], but since the precise statement given in Theorem 2.7 cannot be directly read off from existing results in the literature, we provide in Appendix B a proof of Theorem 2.7 as a logical consequence of [PYY22, Theorem A] by using suspension flows. □

In our setting, we have $\mathcal{C}^p = \mathcal{C}^s = \mathcal{B}$, and then Proposition 2.6 provides condition (I), the Walters property implies condition (II), and equation (2.2) provides condition (III), so Theorem 2.7 applies and we can conclude that there is a unique equilibrium measure, and that $\overline{Q} < \infty$.

We will also need uniform lower counting bounds on \mathcal{G} ; these follow from similar arguments to those in [CT13], but cannot be deduced directly from what is written there, so we provide a proof.

PROPOSITION 2.8. *If equation (2.5) holds, then $\overline{Q}(\mathcal{G}) := \overline{\lim}_{n \rightarrow \infty} Q_n(\mathcal{G}) > 0$.*

Proof. Using the decomposition $\mathcal{B}\mathcal{G}\mathcal{B}$ provided by Proposition 2.6, we have

$$Q_n(\mathcal{L}) \leq \sum_{i+j+k=n} Q_i(\mathcal{B})Q_j(\mathcal{G})Q_k(\mathcal{B}) = \sum_{\ell=0}^n Q_{n-\ell}(\mathcal{G}) \sum_{i=0}^{\ell} Q_i(\mathcal{B})Q_{\ell-i}(\mathcal{B}). \tag{2.9}$$

Let $R_\ell(\mathcal{B}) := \sum_{i=0}^\ell Q_i(\mathcal{B})Q_{\ell-i}(\mathcal{B})$, and observe that just as in equation (2.8), we have

$$\sum_{\ell=0}^\infty R_\ell(\mathcal{B}) = \left(\sum_{i=0}^\infty Q_i(\mathcal{B}) \right)^2 < \infty. \tag{2.10}$$

Thus, $S := \max_\ell R_\ell(\mathcal{B}) < \infty$. Since $\overline{Q} < \infty$, we have $K := \max_j Q_j(\mathcal{G}) < \infty$. By equation (2.10), there is $N \in \mathbb{N}$ such that $\sum_{\ell=N}^\infty R_\ell(\mathcal{B}) < 1/(2K)$, so if $n > N$, using equation (2.9) and recalling equation (1.17), we obtain

$$\begin{aligned} 1 \leq Q_n(\mathcal{L}) &\leq \sum_{\ell=0}^n Q_{n-\ell}(\mathcal{G})R_\ell(\mathcal{B}) \leq \sum_{\ell=0}^{N-1} Q_{n-\ell}(\mathcal{G})S + \sum_{\ell=N}^n KR_\ell(\mathcal{B}) \\ &\leq SN \max\{Q_j(\mathcal{G}) : n - N < j \leq n\} + K/(2K). \end{aligned}$$

The last term is equal to $\frac{1}{2}$; subtracting it from both sides and dividing by SN gives

$$\max\{Q_j(\mathcal{G}) : n - N < j \leq n\} \geq 1/(2SN).$$

Since $n > N$ was arbitrary, this proves Proposition 2.8. □

We have now completed Step 2 of the proof, and proceed to Step 3, the task of obtaining lower bounds on m_x^u and m_x^s when $x \in [v]^+$. With Proposition 2.8 in hand, we can obtain these using Theorem 1.5; to show that both of these measures are non-zero, it suffices to show that $\overline{Q}_x^\pm > 0$ for all $x \in [v]^+$.

Fix $x \in [v]^+$ and let $u \in \mathcal{L}$ be as in Lemma 2.5 (so $vu v \in \mathcal{L}$). Given $w \in \mathcal{G}$, let y_w be the periodic sequence $\dots u w u . w u w u \dots$, and let $z_w = [x, y_w] \in W_{\text{loc}}^u(x) \cap [w]^+$. Thus,

$$\Phi_x^+(w) \geq S_{|w|}\varphi(z_w) \geq \Phi(w) - C, \tag{2.11}$$

where C is the constant from the Bowen property. From the definitions of $\Lambda_n^+(x)$ and \overline{Q}_x^+ in equations (1.19) and (1.20), we now have

$$\overline{Q}_x^+ = \overline{\lim}_{n \rightarrow \infty} \sum_{w \in \mathcal{L}_n} e^{\Phi_x^+(w) - nP} \geq \overline{\lim}_{n \rightarrow \infty} \sum_{w \in \mathcal{G}_n} e^{\Phi(w) - C - nP} = e^{-C} \overline{Q}(\mathcal{G}) > 0.$$

By Theorem 1.5, this implies that $m_x^u(W_{\text{loc}}^u(x)) \geq e^{-C} \overline{Q}(\mathcal{G}) / \overline{Q} > 0$.

The argument for m_x^s is similar: fix $x \in [v]^+$ and given $w \in \mathcal{G}$, let $z_w = [y_w, x] \in W_{\text{loc}}^s(x) \cap [w u]^-$. In place of equation (2.11), we have

$$\Phi_x^-(w u) \geq S_{|w u|}\varphi(\sigma^{-|w u|}(z_w)) \geq \Phi(w u) - C,$$

and we get

$$\begin{aligned} \overline{Q}_x^- &\geq \overline{\lim}_{n \rightarrow \infty} \sum_{w \in \mathcal{G}_n} e^{\Phi(w u) - C - (n+|u|)P} \\ &\geq \overline{\lim}_{n \rightarrow \infty} \sum_{w \in \mathcal{G}_n} e^{\Phi(w) + \Phi(u) - 2C - nP - |u|P} \geq e^{\Phi(u) - 2C - |u|P} \overline{Q}(\mathcal{G}) > 0. \end{aligned}$$

This completes Step 3 of the proof; we have now shown that $\lambda([v]^+) = 0$.

Proceeding to Step 4, we show integrability of the return time by using equation (2.5) and the Gibbs bound in equation (1.41) from Corollary 1.21; note that the constant $K = (\#A)e^{2C} \underline{Q}^2$ appearing there is finite because $\overline{Q} < \infty$. Writing $Y_n = \{x \in [v]^+ : \tau(x) > n\}$, we observe that

$$Y_n \subset \bigcup_{u \in \mathcal{B}_n} [vu]^+$$

(note that the cylinder is empty if $vu \notin \mathcal{L}$), and thus equation (1.41) gives

$$\begin{aligned} \lambda(Y_n) &\leq \sum_{u \in \mathcal{B}_n} \lambda([vu]^+) \leq \sum_{u \in \mathcal{B}_n} K e^{\Phi(vu) - |vu|P} \\ &\leq \sum_{u \in \mathcal{B}_n} K e^{\Phi(v) + \Phi(u) - |v|P - |u|P} = e^{\Phi(v) - |v|P} Q_n(\mathcal{B}). \end{aligned}$$

Thus, the integral of the return time is

$$\int \tau \, d\lambda = \sum_{n=0}^{\infty} \lambda(Y_n) \leq e^{\Phi(v) - |v|P} \sum_{n=0}^{\infty} Q_n(\mathcal{B}) < \infty.$$

Moreover, given any word $w \in \mathcal{L}$ that begins and ends with v , we have $[w]^+ \subset [v]^+ = R$, so $\mu([w]^+) = \lambda([w]^+)$, and Corollary 1.21 implies the second inequality in equation (2.3). The first inequality in equation (2.3) follows from equation (1.39) in Theorem 1.20, the specification property for \mathcal{G} and the Walters property for φ , and the counting bounds in Proposition 2.8. This completes Step 4.

For the completion of the proof, Step 5, it suffices to check the conditions of Theorem 1.19. We showed in Step 3 that λ is positive, in Step 4 that $\int \tau \, d\lambda < \infty$, and in Step 2 that $\overline{Q} < \infty$. Thus, Theorem 1.19 applies, showing that the measure μ defined in equation (1.35) is positive, finite, σ -invariant, and its normalization is an equilibrium measure with local product structure. Since we proved earlier that there is a unique equilibrium measure, this completes the proof of Theorem 2.2.

3. Weights for leaf measures in Theorem 1.5

Observe that for any potential φ , if $\bar{\varphi} = \varphi - P(\varphi)$, then $P(\bar{\varphi}) = 0$. Moreover, under this construction, φ and $\bar{\varphi}$ produce the same equilibrium measure as

$$\Phi_x^+(w) - |w|P(\varphi) = \bar{\Phi}_x^+(w) = \sup\{S_{|w|}\bar{\varphi}(y) : y \in [w]^+ \cap W_{loc}^u(x)\}.$$

To simplify the notation in the proofs, we will replace φ with $\bar{\varphi}$ and make the following assumption for the remainder of the paper.

$$\text{Standing Assumption : } P = 0. \tag{3.1}$$

For non-zero pressure, the work is similar where an additional term including the pressure would be included. For example, wherever a $\Phi_x^\pm(w)$ or $\varphi(x)$ appears, one would need to include $\Phi_x^\pm(w) - |w|P$ or $\varphi(x) - P$, respectively.

Equations (1.21) and (1.22) are equivalent results. By proving one result, one can prove the other by reversing the direction of the shift. In this section, we will prove the bounds on the weights of the unstable leaf measure in equation (1.21).

To obtain these bounds, we first need to establish a pair of inequalities, which should be compared with equation (1.8). First, recall from equation (1.36) that for $x \in X$ and $w \in \mathcal{L}_n$ with $[w]^+ \cap W_{\text{loc}}^u(x) \neq \emptyset$, we write $x.w = \cdots x_{-2}x_{-1}w_1w_2 \cdots w_n$, and define

$$\Phi_{x.w}(u) = \sup\{S_{|u|}\varphi(y) : y \in W_{\text{loc}}^u(x.wu_1) \cap [u]^+\}.$$

LEMMA 3.1. For $w, u, v \in \mathcal{L}$ such that $wu \in \mathcal{L}$ and $uv \in \mathcal{L}$,

$$\Phi_x^+(wu) \leq \Phi_x^+(w) + \Phi_{x.wu_1}^+(u), \tag{3.2}$$

$$\Phi_x^+(uv) \geq \Phi_x^+(u) + \Phi_{x.uv_1}^+(v) - V_x^+(u), \tag{3.3}$$

where $V_x^+(u) = \sup_{y,z \in W_{\text{loc}}^u(x) \cap [u]^+} (S_{|u|}\varphi(y) - S_{|u|}\varphi(z))$.

Proof. Let $y \in W_{\text{loc}}^u(x) \cap [wu]^+$ and observe that

$$S_{|wu|}\varphi(y) = S_{|w|}\varphi(y) + S_{|u|}\varphi(\sigma^{|w|}y).$$

If $y' \in W_{\text{loc}}^u(x) \cap [w]^+$ and $z \in W_{\text{loc}}^u(x.wu_1) \cap [u]^+$, then taking supremums yields

$$\begin{aligned} \Phi_x^+(wu) &= \sup_y S_{|wu|}\varphi(y) \leq \sup_{y',z} S_{|w|}\varphi(y') + S_{|u|}\varphi(\sigma^{|w|}z) \\ &= \Phi_x^+(w) + \Phi_{x.wu_1}^+(u). \end{aligned}$$

Similarly, if $y \in [uv]^+$ and $y' \in W_{\text{loc}}^u(x) \cap [u]^+$, we have

$$\begin{aligned} S_{|u|}\varphi(y) + S_{|v|}\varphi(\sigma^{|v|}y) &= S_{|u|}\varphi(y) - S_{|u|}\varphi(y') + S_{|u|}\varphi(y') + S_{|v|}\varphi(\sigma^{|u|}y) \\ &\geq -V_x^+(u) + S_{|u|}\varphi(y') + S_{|v|}\varphi(\sigma^{|u|}y). \end{aligned}$$

If $z \in W_{\text{loc}}^u(x.uv_1) \cap [v]^+$, then taking supremums gives us

$$\begin{aligned} \Phi_x^+(uv) &= \sup_y S_{|u|}\varphi(y) + S_{|v|}\varphi(\sigma^{|v|}y) \geq \sup_{y',z} -V_x^+(u) + S_{|u|}\varphi(y') + S_{|v|}\varphi(z) \\ &= \Phi_x^+(u) + \Phi_{x.uv_1}(v) - V_x^+(u), \end{aligned}$$

since every $z \in W_{\text{loc}}^u(x.uv_1) \cap [v]^+$ is equal to $\sigma^{|u|}y$ for some $y \in W_{\text{loc}}^u(x) \cap [uv]^+$. \square

Now we prove the inequalities in Theorem 1.5 for unstable leaves.

Proof. We begin with the proof of the upper bound in equation (1.21). For all $n \in \mathbb{N}$, we have $W_{\text{loc}}^u(x) \subset X = \bigcup_{u \in \mathcal{L}_n} [u]^+$, so $\mathcal{L}_n \in \mathbb{E}^+(W_{\text{loc}}^u(x), N)$ whenever $n \geq N$. Thus,

$$\inf \left\{ \sum_{u \in \mathcal{E}} e^{\Phi_x^+(u)} : \mathcal{E} \in \mathbb{E}^+(W_{\text{loc}}^u(x), N) \right\} \leq \sum_{u \in \mathcal{L}_n} e^{\Phi_x^+(u)} = \Lambda_n^+(x). \tag{3.4}$$

Sending $n \rightarrow \infty$ along an arbitrary subsequence and recalling equation (1.20), this gives

$$m_x^u(W_{\text{loc}}^u(x)) \leq \underline{Q}_x^+,$$

which proves the upper bound in equation (1.21).

For the lower bound in equation (1.21), we begin by finding an inequality for expressing a fixed cylinder as a disjoint union of longer cylinders of some uniform length. Writing

$\mathcal{S}_n(x.u) := \{v \in \mathcal{L}_n : [v]^+ \cap W_{\text{loc}}^u(x.u) \neq \emptyset\}$, then by the inequality in equation (3.2), we have

$$\begin{aligned} \sum_{v \in \mathcal{S}_n(x.u)} e^{\Phi_x^+(uv)} &\leq \sum_{v \in \mathcal{S}_n(x.u)} e^{\Phi_x^+(u) + \Phi_{x.uv_1}^+(v)} = e^{\Phi_x^+(u)} \sum_{v \in \mathcal{S}_n(x.u)} e^{\Phi_{x.uv_1}^+(v)} \\ &\leq e^{\Phi_x^+(u)} \sum_{v \in \mathcal{L}_n} e^{\Phi(v)} = e^{\Phi_x^+(u)} Q_n. \end{aligned}$$

This implies that

$$(Q_n)^{-1} \sum_{v \in \mathcal{S}_n(x.u)} e^{\Phi_x^+(uv)} \leq e^{\Phi_x^+(u)}. \tag{3.5}$$

Next, we will take a cover of $W_{\text{loc}}^u(x)$ and lengthen the words of the cylinders so they are all the same length, then apply the bound in equation (3.5).

By compactness of $W_{\text{loc}}^u(x)$, it suffices to consider only finite covers of $W_{\text{loc}}^u(x)$ in estimating $m_x^u(W_{\text{loc}}^u(x))$. Given such a finite cover \mathcal{E} and any $n \geq \max\{|u| : u \in \mathcal{E}\}$ (which is finite since \mathcal{E} is), we produce a new cover $\{uv : u \in \mathcal{E}, v \in \mathcal{S}_{n-|u|}(x.u)\}$. All words of this new cover have length n . Now equation (3.5) gives

$$\sum_{u \in \mathcal{E}} e^{\Phi_x^+(u)} \geq \sum_{u \in \mathcal{E}} (Q_{n-|u|})^{-1} \sum_{v \in \mathcal{S}_{n-|u|}(x.u)} e^{\Phi_x^+(uv)}. \tag{3.6}$$

We desire to find a bound for the $Q_{n-|u|}$ so that we can factor it out of the sum. For all $Q > \bar{Q}$, there exists an n_0 such that $Q > Q_k$ for all $k \geq n_0$. If we restrict n to be greater than $n_0 + \max_{u \in \mathcal{E}} |u|$, then equation (3.6) implies that

$$\sum_{u \in \mathcal{E}} e^{\Phi_x^+(u)} \geq Q^{-1} \sum_{u \in \mathcal{E}} \sum_{v \in \mathcal{S}_{n-|u|}(x.u)} e^{\Phi_x^+(uv)} \geq Q^{-1} \sum_{w \in \mathcal{L}_n} e^{\Phi_x^+(w)}. \tag{3.7}$$

The new index in the last step follows from the fact that for each u , the word uv has length n , and the collection of $[uv]^+$ covers $W_{\text{loc}}^u(x)$. Additionally, any word $w \in \mathcal{L}_n$ such that $W_{\text{loc}}^u(x) \cap [w]^+ = \emptyset$ does not contribute to the sum.

By taking an arbitrary subsequence $n_k \rightarrow \infty$ in equation (3.7), we have

$$m_x^u(W_{\text{loc}}^u(x)) \geq Q^{-1} \bar{Q}_x^+.$$

Since $Q > \bar{Q}$ was arbitrary, this proves the lower bound in equation (1.21). □

The proof for equation (1.22) is analogous.

4. Scaling of leaf measures in Theorem 1.6

We will prove the scaling property in Theorem 1.6 for unstable leaves by proving a preliminary lemma. The approach for the stable setting is identical by reversing the direction of the shift.

We will use the notation $\varphi(x) = c \pm \epsilon$ as a shorthand for $c - \epsilon \leq \varphi(x) \leq c + \epsilon$.

LEMMA 4.1. *Let $Z \subset W_{\text{loc}}^u(x)$ such that $\sigma Z \subset W_{\text{loc}}^u(\sigma x)$. Assume further that there is a constant $c \in \mathbb{R}$ and $N_0 \in \mathbb{N}$ such that for any $w \in \mathcal{L}_{\geq N_0}$ with $[w]^+ \cap Z \neq \emptyset$, we have that $\varphi(y) = c \pm \epsilon$ for all $y \in [w]^+ \cap W_{\text{loc}}^u(x)$. Then we have*

$$m_{\sigma x}^u(\sigma Z) = e^{\pm 2\epsilon} \int_Z e^{-\varphi(y)} dm_x^u(y).$$

Proof. If $|w| \geq N_0$, we have that $\varphi(x) = c \pm \epsilon$ on $[w]^+$, so

$$\begin{aligned} \Phi_x^+(w) &= \sup\{\mathcal{S}_{|w|}\varphi(y) : y \in [w]^+ \cap W_{\text{loc}}^u(x)\} \\ &= \sup\{\mathcal{S}_{|w|-1}\varphi(\sigma y) + c \pm \epsilon : y \in [w]^+ \cap W_{\text{loc}}^u(x)\} \\ &= c \pm \epsilon + \sup\{\mathcal{S}_{|w|-1}\varphi(y') : y' \in [\sigma w]^+ \cap W_{\text{loc}}^u(\sigma x)\} \\ &= c \pm \epsilon + \Phi_{\sigma x}^+(\sigma w). \end{aligned} \tag{4.1}$$

Because $\sigma(Z) \subset W_{\text{loc}}^u(\sigma x)$ for any $z \in Z$, the symbol $z_1 = x_1$. This implies that for a sufficiently long word w such that $[w]^+ \cap Z$, the map σ is a bijection between $[w]^+ \cap W_{\text{loc}}^u(x)$ and $[\sigma w]^+ \cap W_{\text{loc}}^u(\sigma x)$.

Moreover, σ acts as a bijection between covers in $\mathbb{E}^+(Z, N)$ and $\mathbb{E}^+(\sigma Z, N - 1)$. That is, if $w \in \mathcal{E}$ for some cover in $\mathbb{E}^+(Z, N)$, then $[\sigma w]^+ \cap \sigma Z \neq \emptyset$. Likewise, if $w \in \mathcal{E}'$ for some cover in $\mathbb{E}(\sigma Z, N - 1)$, then $[x_0 w]^+ \cap Z \neq \emptyset$.

Using equation (4.1) in the definition of $m_x^u(Z)$ for $N > N_0$, we get

$$\begin{aligned} m_x^u(Z) &= \lim_{N \rightarrow \infty} \inf \left\{ \sum_{w \in \mathcal{E}} e^{\Phi_x^+(w)} : \mathcal{E} \in \mathbb{E}^+(Z, N) \right\} \\ &= \lim_{N \rightarrow \infty} \inf \left\{ \sum_{w \in \mathcal{E}} e^{c \pm \epsilon + \Phi_{\sigma x}^+(\sigma w)} : \mathcal{E} \in \mathbb{E}^+(Z, N) \right\} \\ &= e^{c \pm \epsilon} \lim_{N \rightarrow \infty} \inf \left\{ \sum_{u \in \mathcal{E}'} e^{\Phi_{\sigma x}^+(u)} : \mathcal{E}' \in \mathbb{E}^+(\sigma Z, N - 1) \right\} \\ &= e^{c \pm \epsilon} m_{\sigma x}^u(\sigma Z), \end{aligned} \tag{4.2}$$

where $u = \sigma w$. Additionally, because $\varphi(y) = c \pm \epsilon$ on Z , we have that

$$\int_Z e^{-\varphi(y)} dm_x^u(y) = \int_Z e^{-c \pm \epsilon} dm_x^u(y) = e^{-c \pm \epsilon} m_x^u(Z). \tag{4.3}$$

Combining the result from equation (4.2) and equation (4.3), we get

$$\int_Z e^{-\varphi(y)} dm_x^u(y) = e^{-c \pm \epsilon} m_x^u(Z) = e^{-c \pm \epsilon} e^{c \pm \epsilon} m_{\sigma x}^u(\sigma Z) = e^{\pm 2\epsilon} m_{\sigma x}^u(\sigma Z),$$

which completes the proof of the lemma. □

To prove Theorem 1.6, we consider a set $Z \subset W_{\text{loc}}^u(x)$ satisfying $\sigma Z \subset W_{\text{loc}}^u(\sigma x)$. For $\epsilon > 0$, let $Z_n = Z \cap \varphi^{-1}([n\epsilon/2, (n + 1)\epsilon/2])$ and note that the sets Z_n are measurable, mutually disjoint, and $Z = \bigcup_{n \in \mathbb{Z}} Z_n$. Moreover, since φ is uniformly continuous, there is $N \in \mathbb{N}$ such that $|\varphi(y) - \varphi(z)| < \epsilon/2$ whenever $y_{[-N, N]} = z_{[-N, N]}$, and in particular,

given any $w \in \mathcal{L}$ with $|w| \geq N$ and $[w]^+ \cap Z_n \neq \emptyset$, we can fix $y \in [w]^+ \cap Z_n$ and observe that any $z \in [w]^+ \cap W_{\text{loc}}^u(x)$ has

$$|\varphi(z) - n\epsilon/2| \leq |\varphi(z) - \varphi(y)| + |\varphi(y) - n\epsilon/2| \leq \epsilon/2 + \epsilon/2 = \epsilon.$$

Thus, each Z_n satisfies the conditions of Lemma 4.1, so

$$m_{\sigma_x}^u(\sigma Z) = \sum_{n \in \mathbb{Z}} m_{\sigma_x}^u(\sigma Z_n) = e^{\pm 2\epsilon} \sum_{n \in \mathbb{Z}} \int_{Z_n} e^{-\varphi(y)} dm_x^u(y) = e^{\pm 2\epsilon} \int_Z e^{-\varphi(y)} dm_x^u(y).$$

Letting $\epsilon \rightarrow 0$ proves equation (1.23). The proof of equation (1.24) is analogous.

5. Uniformly continuous holonomies; proof of Theorem 1.15

In this section, we prove the results in §1.8 about uniformly continuous holonomies, starting with Propositions 1.9 and 1.10, then proceeding to Theorem 1.15.

5.1. Examples with uniformly continuous holonomies. Propositions 1.9 and 1.10 both rely on the following fact.

LEMMA 5.1. Given any rectangle R , any $y, z \in R$, and any $Y \subset W_R^u(y)$, we have $\mathbb{E}^+(Y, N) = \mathbb{E}^+(\pi_{y,z}^s(Y), N)$ for all $N \in \mathbb{N}$.

Proof. Given any $N \in \mathbb{N}$ and $\mathcal{E} \in \mathbb{E}^+(Y, N)$, for every $x \in \pi_{y,z}^s(Y)$, we have $x' = (\pi_{y,z}^s)^{-1}(x) \in Y$ and thus $x' \in [w]^+$ for some $w \in \mathcal{E}$, but since $x' \in W_{\text{loc}}^s(x)$, this implies that $x \in [w]^+$ as well, so $\mathcal{E} \in \mathbb{E}^+(\pi_{y,z}^s(Y), N)$. This proves one inclusion, and the other follows by symmetry. □

With this lemma in hand, Proposition 1.10 (the case $\varphi \equiv 0$) is easy to prove.

Proof of Proposition 1.10. By Lemma 5.1, we have $\mathbb{E}^+(Y, N) = \mathbb{E}^+(\pi_{y,z}^s(Y), N)$. For every $\mathcal{E} \in \mathbb{E}^+(Y, N)$ and every $w \in \mathcal{E}$, we have $\Phi_y^+(w) = \Phi_z^+(w) = -|w|P$ since $\varphi \equiv 0$, and thus $\sum_{w \in \mathcal{E}} e^{\Phi_y^+(w)} = \sum_{w \in \mathcal{E}} e^{\Phi_z^+(w)}$. Taking an infimum over all such \mathcal{E} gives $m_y^u(Y) = m_z^u(\pi_{y,z}^s(Y))$. □

Now we prove uniform continuity of holonomies for open rectangles when φ has the Walters property.

Proof of Proposition 1.9. By the Walters property, given $\epsilon > 0$, there is $k \in \mathbb{N}$ such that for all $n \in \mathbb{N}$ and $y, z \in R$ with $y_i = z_i$ for all $i \geq -k$, we have $|S_n\varphi(y) - S_n\varphi(z)| \leq \epsilon$ for all $n \in \mathbb{N}$. We claim that $\delta = 2^{-k}$ satisfies the required conclusion in Definition 1.8; that is, that for any open rectangle R and any $y, z \in R$ with $d(y, z) < \delta$, we have $m_y^u(Y) = e^{\pm\epsilon} m_z^u(\pi_{y,z}^s(Y))$ for all measurable $Y \subset W_R^u(y)$.

It suffices to show this conclusion in the case when $R = [u]^- \cap [v]^+$ for some $u, v \in \mathcal{L}$. Indeed, any open rectangle R can be written as a disjoint union $R = \bigsqcup_{i=1}^\infty R_i$, where each R_i is of the form $[u]^- \cap [v]^+ \cap R = [u]^- \cap [v]^+$, and then if we have the result

for each R_i , we can deduce that if $d(y, z) < \delta$, then there are $y_i \in W_R^u(y) \cap R_i$ and $z_i \in W_R^u(z) \cap R_i$ such that $d(y_i, z_i) < \delta$, so

$$m_y^u(Y) = \sum_{i=1}^{\infty} m_{y_i}^u(Y \cap R_i) = \sum_{i=1}^{\infty} e^{\pm\epsilon} m_{z_i}^u(\pi_{y,z}^s(Y) \cap R_i) = e^{\pm\epsilon} m_z^u(\pi_{y,z}^s(Y)).$$

To prove the conclusion when $R = [u]^- \cap [v]^+$, we observe that given any $w \in \mathcal{L}$ with $|w| \geq |v|$ and $[w]^+ \cap R \neq \emptyset$, we in fact have $[u]^- \cap [w]^+ \subset R$. Given any $x \in W_R^u(y) \cap [w]^+$, we have $x' := \pi_{y,z}^s(x) \in W_R^u(z) \cap [w]^+$ and so $x_i = x'_i$ for all $i \geq -k$. By the Walters property, this implies that

$$|S_n \varphi(x) - S_n \varphi(x')| \leq \epsilon \text{ for all } n \in \mathbb{N}.$$

Taking a supremum over all $x \in W_R^u(y) \cap [w]^+$ gives $\Phi_x^+(w) \leq \Phi_{x'}^+(w) + \epsilon$, and by the symmetrical result with x, x' reversed, we get

$$\Phi_x^+(w) = \Phi_{x'}^+(w) \pm \epsilon. \tag{5.1}$$

(Note that this step is where we use the openness of R in an essential way; the argument would fail if we did not have $[u]^- \cap [w]^+ \subset R$, since then the holonomy map would only be defined on $W_{\text{loc}}^u(x) \cap [w]^+ \cap R$, which might not be all of $W_{\text{loc}}^u(x) \cap [w]^+$.)

Fix $Y \subset W_R^u(y)$ and let $N \geq |w|$. Then any cover $\mathcal{E} \in \mathbb{E}^+(Y, N)$ is also a cover of $\pi_{y,z}^s(Y) \subset W_R^u(z)$ and *vice versa*, by the product structure, and equation (5.1) gives

$$\sum_{w \in \mathcal{E}} e^{\Phi_y^+(w)} = \sum_{w \in \mathcal{E}} e^{\Phi_z^+(w) \pm \epsilon}.$$

Taking an infimum over covers in $\mathbb{E}^+(Y, N)$ (and hence also over $\mathbb{E}^+(\pi_{y,z}^s(Y), N)$) and then sending $N \rightarrow \infty$ gives $m_y^u(Y) = e^{\pm\epsilon} m_z^u(\pi_{y,z}^s(Y))$. This proves the conclusion when $R = [u]^- \cap [v]^+$, and by the discussion at the start of the proof, taking countable unions of such rectangles gives the result for arbitrary open rectangles. \square

5.2. *Proof of Theorem 1.15.* Now we prove Theorem 1.15 that uniform continuity of holonomies is equivalent to uniform convergence and boundedness of Δ^s together with equation (1.31) for the Radon–Nikodym derivative of the holonomy map.

Before proving the equivalence, we observe an important consequence of the positivity condition in Definition 1.14; given any $R \in \mathcal{R}$, any $x \in R$, and any $w \in \mathcal{L}$ such that $[w]^+ \cap W_R^u(x) \neq \emptyset$, we fix $y \in [w]^+ \cap W_R^u(x)$ and get $\sigma^n(y) \in \sigma^n(R \cap [w]^+)$, which is itself a rectangle in \mathcal{R} by \mathcal{L} -invariance, and thus

$$m_{\sigma^n(y)}^u(\sigma^n(R \cap [w]^+)) > 0$$

by positivity. Applying equation (1.26), we see that $m_x^u([w]^+) = m_y^u([w]^+) > 0$, and conclude that m_x^u is fully supported in the following sense.

LEMMA 5.2. *If \mathcal{R} is an \mathcal{L} -invariant family of rectangles on which the family of leaf measures m_x^u is positive, then for every $R \in \mathcal{R}$ and $x \in R$, the measure m_x^u gives positive weight to every (relatively) open set in $W_R^u(x)$.*

Now we prove the equivalence of the two conditions in Theorem 1.15. Start by assuming that Δ^s converges uniformly and that equation (1.31) is the Radon–Nikodym derivative. (In fact, uniform convergence of Δ^s implies boundedness, see Lemma 5.3.) We must prove uniform continuity of holonomies.

Observe that each partial sum $\sum_{n=0}^N (\varphi(\sigma^n x') - \varphi(\sigma^n x))$ is uniformly continuous, and thus by uniform convergence, Δ^s is uniformly continuous as well. Since $\Delta^s(x, x) = 0$, this implies that given $\delta > 0$, there exists $N \in \mathbb{N}$ such that given any $x, x' \in R \in \mathcal{R}$ satisfying $x_i = x'_i$ for all $i \geq -N$, we have $|\Delta^s(x', x)| < \delta$.

Now given any $y, z \in R$ with $d(y, z) < 2^{-N}$, we have $y_i = z_i$ for all $|i| \leq N$, and thus given any $x \in W_R^u(y)$ and $x' = \pi_{y,z}^s(x)$, we have $x_i = x'_i$ for all $i \geq -N$. Using equation (1.31), it follows that for every $Y \subset W_R^u(y)$, we have

$$m_z^u(\pi_{y,z}^s(Y)) = \int_Y e^{\Delta^s([z,x],x)} dm_y^u(x) = \int_Y e^{\pm\delta} dm_y^u(x) = e^{\pm\delta} dm_y^u(Y).$$

Conversely, suppose that the leaf measures have uniformly continuous holonomies on \mathcal{R} . Let $y \in R$ and fix $\delta > 0$. There exists an $N_0 \in \mathbb{N}$ such that if $y'_i = y_i$ for all $i \geq -N_0$, then

$$m_y^u(Y) = e^{\pm\delta} m_{y'}^u(\pi_{y,y'}^s(Y)). \tag{5.2}$$

Choose $Y \subset W_R^u(y)$ such that $\sigma^N(Y) \subset W_{\text{loc}}^u(\sigma^N y)$. For simplicity, consider $z \in W_R^s(y)$, and note that given any $N \geq N_0$, we have $(\sigma^N z)_i = (\sigma^N y)_i$ for all $i \geq -N$ and hence for all $i \geq -N_0$. Thus, equation (5.2) gives

$$m_{\sigma^N y}^u(\sigma^N Y) = e^{\pm\delta} m_{\sigma^N z}^u(\pi_{y,z}^s(\sigma^N Y)). \tag{5.3}$$

Using equation (1.23) twice and equation (5.3) once, we get

$$\begin{aligned} m_z^u(\pi_{y,z}^s(Y)) &= \int_{\sigma^N(\pi_{y,z}^s(Y))} e^{S_N\varphi(\sigma^{-N}x)} dm_{\sigma^N z}^u(x) \\ &= e^{\pm\delta} \int_{\sigma^N(Y)} e^{S_N\varphi(\sigma^{-N}[\sigma^N z,x])} dm_{\sigma^N y}^u(x) \\ &= e^{\pm\delta} \int_Y e^{S_N\varphi(\sigma^{-N}[\sigma^N z,\sigma^N x]) - S_N\varphi(x)} dm_y^u(x) \\ &= e^{\pm\delta} \int_Y e^{S_N\varphi([x,z]) - S_N\varphi(x)} dm_y^u(x). \end{aligned}$$

The last line follows because for any $x \in W_{\text{loc}}^u(y) \cap Y$, we have that $x_{[0,N]} = y_{[0,N]} = z_{[0,N]}$ as $\sigma^N(Y) \subset W_{\text{loc}}^u(\sigma^N y)$ and $z \in W_R^s(y)$. Thus, $\sigma^N[\sigma^{-N}x, \sigma^{-N}z] = [x, z]$.

Since every $Y \subset W_R^u(y)$ can be decomposed as a disjoint union of sets that lie in a cylinder of length N , we conclude that with $N_0 = N_0(\delta)$ as above, if we write $\Delta_N(x', x) := S_N\varphi(x') - S_N\varphi(x)$, then we have

$$m_z^u(\pi_{y,z}^s(Y)) = e^{\pm\delta} \int_Y e^{\Delta_N([x,z],x)} dm_y^u(x) \tag{5.4}$$

for every y, z, x , every measurable $Y \subset W_R^u(y)$, and every $N \geq N_0$. Thus, for every $N, N' \geq N_0$, we have

$$\int_Y e^{\Delta_N([x,z],x)} dm_y^u(x) = e^{\pm 2\delta} \int_Y e^{\Delta_{N'}([x,z],x)} dm_y^u(x). \tag{5.5}$$

Since m_y^u gives positive weight to every relatively open set in $W_R^u(y)$ by Lemma 5.2, a standard argument shows that $\Delta_N([x, z], x) = \Delta_{N'}([x, z], x) \pm 2\delta$ for all $x \in W_R^u(y)$; indeed, if this inequality fails at any point, then by continuity, there is a relatively open set Y on which it fails uniformly, and since $m_y^u(Y) > 0$, this would violate the integral estimates in equation (5.5).

We have proved that Δ_N is uniformly Cauchy: for every $\delta > 0$, there is $N_0 \in \mathbb{N}$ such that for every $R \in \mathcal{R}$, every $y, z \in R$, every $x \in W_R^u(y)$, and every $N, N' \geq N_0$, we have

$$|\Delta_N([x, z], x) - \Delta_{N'}([x, z], x)| \leq 2\delta.$$

In particular, given any $x, x' \in R$ with $x' \in W_R^s(x)$, we can choose $y = x$ and $z = x'$ to deduce that

$$|\Delta_N(x', x) - \Delta_{N'}(x', x)| \leq 2\delta.$$

This proves that Δ_N converges uniformly to Δ^s on $\{(x, x') \in R^2 : R \in \mathcal{R}, x' \in W_R^s(x)\}$, and then equation (5.4) gives

$$m_z^u(\pi_{y,z}^s(Y)) = e^{\pm \delta} \int_Y e^{\Delta^s([x,z],x)} dm_y^u(x).$$

Since $\delta > 0$ is arbitrary, equation (1.31) follows.

Finally, we observe that uniform convergence of Δ_N implies uniform boundedness, by the following lemma.

LEMMA 5.3. *If the sums in the definitions of $\Delta^{s,u}$ converge uniformly, then there is $C > 0$ such that $|\Delta^s(x, x')| \leq C$ for all $(x, x') \in R^2, R \in \mathcal{R}, x' \in W_R^s(x)$, and similarly for Δ^u .*

Proof. By uniform convergence, there exists $N \in \mathbb{N}$ such that

$$\left| \sum_{k=N}^{\infty} \varphi(\sigma^k x) - \varphi(\sigma^k x') \right| \leq 1$$

for all x, x' as in the statement. Thus,

$$|\Delta^s(x, x')| \leq \sum_{k=0}^{N-1} |\varphi(\sigma^k x) - \varphi(\sigma^k x')| + \left| \sum_{k=N}^{\infty} \varphi(\sigma^k x) - \varphi(\sigma^k x') \right| \leq 2N\|\varphi\| + 1.$$

The proof for Δ^u is analogous. □

6. Equilibrium measures using product structure

In this section, we prove Theorems 1.17, 1.18, and 1.19 from §1.9. Throughout this section, we will assume that \mathcal{R} is an \mathcal{L} -invariant family of rectangles on which the families of leaf measures m_x^u and m_x^s both have uniformly continuous holonomies and are positive in the sense of Definition 1.14.

6.1. *Proof of Theorem 1.17.* By Remark 1.16, the assumption of positivity together with the holonomy results from Theorem 1.15 guarantee that $m_q^u(R) > 0$ and $m_q^s(R) > 0$ for every $q \in R$. This is enough to imply that $m_{R,q}$ from equation (1.32) is non-zero for every $q \in R$, and since $\Delta^{u,s}$ are uniformly bounded by Theorem 1.15, this in turn implies that λ_R is non-zero. It remains to show that λ_R is independent of our choice of $q \in R$.

To this end, let $q, q' \in R$. Recalling that

$$\Delta^u(x', x) := \sum_{n=0}^{\infty} \varphi(\sigma^{-n}x') - \varphi(\sigma^{-n}x),$$

we see that Δ^u has the following additivity property: given any $y \in W_R^s(q)$ and $z \in W_R^u(q)$, we have

$$\Delta^u([y, z], y) = \Delta^u([y, q'], y) + \Delta^u([y, z], [y, q']).$$

Using this and (the m^s -version of) Theorem 1.15, we have

$$\begin{aligned} & \int_{W_R^s(q)} e^{\Delta^u([y,z],y)} e^{\Delta^s([y,z],z)} \mathbf{1}_Z([y, z]) dm_q^s(y) \\ &= \int_{W_R^s(q)} e^{\Delta^u([y,z],[y,q']) + \Delta^u([y,q'],y)} e^{\Delta^s([y,z],z)} \mathbf{1}_Z([y, z]) dm_q^s(y) \\ &= \int_{W_R^s(q)} e^{\Delta^u([y,z],[y,q'])} e^{\Delta^s([y,z],z)} \mathbf{1}_Z([y, z]) d((\pi_{q',q}^u)_* m_{q'}^s)(y). \end{aligned}$$

Given $y \in W_R^s(q)$, let $y' = (\pi_{q',q}^u)^{-1}(y)$; then the above equation gives

$$\begin{aligned} & \int_{W_R^s(q)} e^{\Delta^u([y,z],y)} e^{\Delta^s([y,z],z)} \mathbf{1}_Z([y, z]) dm_q^s(y) \\ &= \int_{W_R^s(q')} e^{\Delta^u([y',z],y')} e^{\Delta^s([y',z],z)} \mathbf{1}_Z([y', z]) dm_{q'}^s(y'). \end{aligned} \tag{6.1}$$

Using equation (6.1) and Fubini's theorem, we get

$$\begin{aligned} \lambda_R(Z) &= \int_{W_R^u(q)} \int_{W_R^s(q)} e^{\Delta^u([y,z],y)} e^{\Delta^s([y,z],z)} \mathbf{1}_Z([y, z]) dm_q^s(y) dm_q^u(z) \\ &= \int_{W_R^s(q')} \int_{W_R^u(q)} e^{\Delta^u([y',z],y')} e^{\Delta^s([y',z],z)} \mathbf{1}_Z([y', z]) dm_q^u(z) dm_{q'}^s(y'). \end{aligned}$$

The argument leading to equation (6.1) lets us replace q with q' in the integral over W^s , provided we also replaced y with $y' = (\pi_{q',q}^s)^{-1}(y)$. A completely analogous argument for the integral over W^u lets us deduce that

$$\lambda_R(Z) = \int_{W_R^s(q')} \int_{W_R^u(q')} e^{\Delta^u([y',z'],y')} e^{\Delta^s([y',z'],z')} \mathbf{1}_Z([y', z']) dm_{q'}^u(z') dm_{q'}^s(y'),$$

where z' and z are related by $z = \pi_{q',q}^u(z')$. We see that using q' instead of q in equations (1.32) and (1.33) would lead to exactly this formula for $\lambda_R(Z)$, and thus we have proved that λ_R is independent of the choice of $q \in R$.

6.2. *Proof of Theorem 1.18.* Now we assume that R is the disjoint union of finitely many rectangles $R_1, \dots, R_\ell \in \mathcal{R}$, and let $\lambda_R = \sum_{i=1}^\ell \lambda_{R_i}$ as in equation (1.34).

Let $R^{(1)} = \{x \in R : \tau(x) < \infty\}$ be the set on which T is defined; observe that $\lambda_R(R \setminus R^{(1)}) = 0$ by hypothesis. Define $R^{(n)}$ as the set of points in $R^{(1)}$ whose forward trajectory stays in $R^{(1)}$ for $n - 1$ steps, that is, by $R^{(n)} = R^{(1)} \cap T^{-1}(R^{(n-1)})$; again we have $\lambda_R(R \setminus R^{(n)}) = 0$ for all n . Let $R^{(\infty)} = \bigcap_{n=1}^\infty R^{(n)}$, so we have $T : R^{(\infty)} \rightarrow R^{(\infty)}$ and $\lambda_R(R \setminus R^{(\infty)}) = 0$. We will show that λ_R is T -invariant on $R^{(\infty)}$.

Given $n \in \mathbb{N}$ and $i, j \in \{1, \dots, \ell\}$, let

$$E_{ij}^n := \tau^{-1}(\{n\}) \cap R_i \cap \sigma^{-n}(R_j).$$

We will prove the following.

LEMMA 6.1. *Given any i, j, n as above, any $w \in \mathcal{L}_n$, and any measurable $Z \subset E_{ij}^n \cap [w]^+$, we have $\lambda_R(T(Z)) = \lambda_R(Z)$.*

Once the lemma is proved, observe that for any measurable $Z \subset R^{(\infty)}$, we have $Z = \bigcup_{i,j,n,w} Z \cap E_{ij}^n \cap [w]^+$ and $T(Z) = \bigcup_{i,j,n,w} T(Z \cap E_{ij}^n \cap [w]^+)$, and thus

$$\lambda_R(T(Z)) = \sum_{i,j,n,w} \lambda_R(T(Z \cap E_{ij}^n \cap [w]^+)) = \sum_{i,j,n,w} \lambda_R(Z \cap E_{ij}^n \cap [w]^+) = \lambda_R(Z),$$

which proves Theorem 1.18. So it only remains to prove Lemma 6.1.

To this end, fix i, j, n, w as above, and let $Z \subset E_{ij}^n \cap [w]^+$ be measurable. Then $Z \subset R_i \cap [w]^+$, and since $\tau(x) = n$ for all $x \in Z$, we have $T(Z) = \sigma^n(Z) \subset R_j$.

Since we assumed that the family \mathcal{R} of rectangles is \mathcal{L} -invariant as in Definition 1.13, the rectangles $\sigma^n(R_i \cap [w]^+)$ and $\sigma^{-n}(R_j \cap [w]^-)$ both lie in \mathcal{R} , and hence by Theorem 1.15, we can use equation (1.31) for holonomies between unstable leaf measures, as well as its analogue for the stable leaf measures.

Recalling equation (1.29), given any $y, z \in E_{ij}^n \cap [w]^+$, we have $\sigma^n y, \sigma^n z \in R_j$ and $[\sigma^n y, \sigma^n z] = \sigma^n[y, z]$.

Fix a reference point $q \in E_{ij}^n \cap [w]^+$. As a consequence of equation (1.24), we have

$$\begin{aligned} & \int_{W_{R_j^s}^s(\sigma^n q) \cap [wq_n]^-} f(y) e^{-\sum_{k=0}^{n-1} \varphi(\sigma^{-k}(y))} dm_{\sigma^n q}^s(y) \\ &= \int_{W_{R_i^s}^s(q)} f(\sigma^n(y)) dm_q^s(y), \end{aligned} \tag{6.2}$$

where f is integrable. Motivated by this expression, observe that if $y \in W_{R_j^s}^s(\sigma^n q)$ and $z \in W_{R_j^u}^u(\sigma^n q)$, then

$$\begin{aligned} & \Delta^u([y, z], y) + \sum_{k=0}^{n-1} \varphi(\sigma^{-k}y) \\ &= \sum_{k=0}^{n-1} \varphi(\sigma^{-k}[y, z]) + \Delta^u(\sigma^{-n}[y, z], \sigma^{-n}y). \end{aligned} \tag{6.3}$$

Similarly, equation (1.23) implies

$$\int_{W_{R_j}^u(\sigma^n q)} f(z) dm_{\sigma^n q}^u(y) = \int_{W_{R_i}^u(q)} f(\sigma^n y) e^{-S_n \varphi(y)} dm_q^u(y). \tag{6.4}$$

Moreover,

$$\begin{aligned} &\Delta^s([y, \sigma^n z], \sigma^n z) - S_n \varphi(z) \\ &= \Delta^s(\sigma^{-n}[y, \sigma^n z], z) - \sum_{k=0}^{n-1} \varphi(\sigma^{-k}[y, \sigma^n z]). \end{aligned} \tag{6.5}$$

Using equation (6.5) followed by equation (6.2) on the integral

$$\int_{W_{R_j}^u(Tq)} \int_{W_{R_j}^s(Tq)} e^{\Delta^u([y,z],y) + \Delta^s([y,z],z)} \mathbf{1}_{T(Z_n(w))}([y, z]) dm_{Tq}^s(y) dm_{Tq}^u(z),$$

the term in the exponent becomes

$$\Delta^u(\sigma^{-n}[\sigma^n y, z], y) + \sum_{k=0}^{n-1} \varphi(\sigma^{-k}[\sigma^n y, z]) + \Delta^s([\sigma^n y, z], z).$$

Then applying equation (6.4) and then equation (6.5), the exponent becomes

$$\begin{aligned} &\Delta^u(\sigma^{-n}([\sigma^n y, \sigma^n z]), y) + \sum_{k=0}^{n-1} \varphi(\sigma^{-k}[\sigma^n y, \sigma^n z]) \\ &+ \Delta^s(\sigma^{-n}([\sigma^n y, \sigma^n z]), z) - \sum_{k=0}^{n-1} \varphi(\sigma^{-k}[\sigma^n y, \sigma^n z]). \end{aligned}$$

Since $\sigma^{-n}([\sigma^n y, \sigma^n z]) = [y, z]$, this term simplifies to

$$\Delta^u([y, z], y) + \Delta^s([y, z], z).$$

For convenience, let

$$\rho(y, z) = e^{\Delta^u([y,z],y) + \Delta^s([y,z],z)}.$$

Altogether, we have shown that given $Z \subset E_{ij}^n \cap [w]^+$, we have

$$\begin{aligned} \lambda_R(TZ) &= \int_{W_{R_j}^u(Tq)} \int_{W_{R_j}^s(Tq)} \rho(y', z') \mathbf{1}_{TZ}[y', z'] dm_{Tq}^s(y') dm_{Tq}^u(z') \\ &= \int_{W_{R_i}^u(q)} \int_{W_{R_i}^s(q)} \rho(y, z) \mathbf{1}_{TZ}[\sigma^n y, \sigma^n z] dm_q^s(y) dm_q^u(z) \\ &= \int_{W_{R_i}^u(q)} \int_{W_{R_i}^s(q)} \rho(y, z) \mathbf{1}_Z[y, z] dm_q^s(y) dm_q^u(z) = \lambda_R(Z). \end{aligned}$$

This proves Lemma 6.1, and as explained in the paragraph following the lemma, we deduce that λ_R is invariant with respect to the return map on $R^{(\infty)}$.

6.3. *Proof of Theorem 1.19.* Now we assume that in addition to the conditions of the previous sections, we have $\int \tau d\lambda_R < \infty$ and $\bar{Q} < \infty$. We must show that the measure μ in equation (1.35) is positive, finite, and σ -invariant, and that $\mu/\mu(X)$ is an equilibrium measure with local product structure.

Positivity of μ is immediate from positivity of λ_R . Finiteness of μ follows from the integrability assumption:

$$\mu(X) = \sum_{n=0}^{\infty} \lambda_R(Y_n) = \sum_{n=0}^{\infty} \lambda_R(\{y \in R : \tau(y) > n\}) = \int \tau d\lambda_R.$$

Shift-invariance of μ follows immediately from T -invariance of λ_R by the usual argument. Finally, local product structure in the sense of Definition 1.2 follows by considering the rectangles R_i together with the rectangles $\sigma^k(E_{ij}^n \cap [w]^+)$ for $w \in \mathcal{L}_n$ and $1 \leq k < n$. So it only remains to show that $\mu/\mu(X)$ is an equilibrium measure. For this, we need the upper Gibbs bound in Corollary 1.21, which implies that for every $w \in \mathcal{L}$ and $1 \leq i \leq \ell$, we have $\lambda_{R_i}([w]^+) \leq Ke^{\Phi(w)}$ (recall we are assuming $P = 0$), and thus

$$\lambda_R([w]^+) \leq \ell Ke^{\Phi(w)}. \tag{6.6}$$

To prove that μ is an equilibrium measure, we will need one more preliminary result. Let $V_j(\varphi) = \sup\{|\varphi(y) - \varphi(z)| : y_{[0,j)} = z_{[0,j)}\}$. Recall $\tau : R^{(\infty)} \rightarrow \mathbb{N}$ is the first return time to R and let $\tau_n(x)$ denote the n th-return time of x to R , defined as

$$\tau_n(x) = \sum_{j=0}^{n-1} \tau(T^j x). \tag{6.7}$$

We will require the following lemma. Note that the dependence of x is in the upper index of the sum and not in the terms of the summand itself as $V_j(\varphi)$ is defined globally.

LEMMA 6.2. *If τ is integrable with respect to λ_R , then*

$$\lim_{n \rightarrow \infty} \frac{1}{n} \sum_{j=0}^{\tau_n(x)-1} V_j(\varphi) = 0 \tag{6.8}$$

for λ_R -almost every (a.e.) $x \in R$.

Proof. For all $\epsilon > 0$, there exists an N_1 such that for all $n \geq N_1$, we get $V_n(\varphi) < \epsilon$ by uniform continuity.

By the Birkhoff ergodic theorem, for λ_R -a.e. x ,

$$\lim_{n \rightarrow \infty} \frac{\tau_n(x)}{n} = \tau_\infty(x) \in L^1(\lambda_R),$$

so there exists an N_2 such that for $n \geq N_2$, we have that $0 \leq \tau_n(x)/n < \tau_\infty(x) + \epsilon$. Additionally, for λ_R -a.e. x , we have that $\tau_\infty(x) < \infty$, so if $n \geq N = \max\{N_1, N_2\}$,

$$\begin{aligned} \frac{1}{n} \sum_{j=0}^{\tau_n(x)-1} V_j(\varphi) &= \frac{1}{n} \sum_{j=0}^{N-1} V_j(\varphi) + \frac{1}{n} \sum_{j=N}^{\tau_n(x)-1} V_j(\varphi) \leq \frac{1}{n} \sum_{j=0}^{N-1} V_j(\varphi) + \frac{1}{n} \sum_{j=N}^{\tau_n(x)-1} \epsilon \\ &= \frac{1}{n} \sum_{j=0}^{N-1} V_j(\varphi) + \frac{\tau_n(x) - N}{n} \epsilon < \frac{1}{n} \sum_{j=0}^{N-1} V_j(\varphi) + \epsilon(\tau_\infty(x) + \epsilon). \end{aligned}$$

Letting $n \rightarrow \infty$, we get

$$\lim_{n \rightarrow \infty} \frac{1}{n} \sum_{j=0}^{\tau_n(x)-1} V_j(\varphi) \leq \epsilon(\tau_\infty(x) + \epsilon).$$

Since ϵ was arbitrary, we get that for λ_R -a.e. $x \in R$,

$$\lim_{n \rightarrow \infty} \frac{1}{n} \sum_{j=0}^{\tau_n(x)-1} V_j(\varphi) = 0. \tag*{\square}$$

To show that μ as defined in equation (1.35) is an equilibrium measure, we will first show that the measure theoretic pressure for λ_R is 0 for the induced system when φ is normalized to have 0 topological pressure. This will imply that the measure theoretic pressure for μ is also 0. We now present the proof of Theorem 1.19.

Proof. Let $\tilde{\varphi}(x) = S_{\tau(x)}\varphi(x)$. If $X_n = \bigcup_{j=0}^{n-1} \sigma^j Z_n$, then

$$\mu(X) \int_{X_n} \varphi \, d\mu = \int_{Z_n} S_n \varphi(x) \, d\lambda_R = \int_{Z_n} \tilde{\varphi} \, d\lambda_R.$$

Hence, $\mu(X) \int_X \varphi \, d\mu = \int_R \tilde{\varphi} \, d\lambda_R$.

Similarly, $\mu(X)h_\mu(\sigma) = h_{\lambda_R}(T)$ by applying Kac’s formula, so we have that

$$\mu(X) \left(h_\mu(\sigma) + \int_X \varphi \, d\mu \right) = h_{\lambda_R}(T) + \int_R \tilde{\varphi} \, d\lambda_R.$$

Since we are assuming that the topological pressure $P(\varphi) = 0$, it is sufficient to show that $h_{\lambda_R}(T) + \int_R \tilde{\varphi} \, d\lambda_R \geq 0$.

Now we use the Shannon–McMillan–Breiman theorem [Gla03, p. 265] to deduce that if we write

$$I_n^{\lambda_R}(x) := -\log(\lambda_R([x_0 \cdots x_{\tau_n(x)-1}]^+)),$$

then there exists an $L^1(\lambda_R)$ function J such that

$$\lim_{n \rightarrow \infty} \frac{1}{n} I_n^{\lambda_R} \rightarrow J \tag{6.9}$$

for λ_R -a.e. x , and

$$\int_R J \, d\lambda_R = h_{\lambda_R}(T).$$

By the Birkhoff ergodic theorem, there exists a function $\tilde{\varphi}_\infty \in L^1(\lambda_R)$ such that

$$\lim_{n \rightarrow \infty} \frac{1}{n} S_n \tilde{\varphi} \rightarrow \tilde{\varphi}_\infty$$

for λ_R -a.e. x , and

$$\int_R \tilde{\varphi} d\lambda_R = \int_R \tilde{\varphi}_\infty d\lambda_R.$$

Using equation (6.6), we get

$$I_n^{\lambda_R}(x) \geq -\log(\ell K) - \Phi(x_0 \cdots x_{\tau_n(x)-1}), \tag{6.10}$$

and rearranging terms, we obtain

$$I_n^{\lambda_R}(x) + \Phi(x_0 \cdots x_{\tau_n(x)-1}) \geq -\log(\ell K),$$

so that in particular,

$$\varliminf_{n \rightarrow \infty} \frac{1}{n} I_n^{\lambda_R}(x) + \frac{1}{n} \Phi(x_0 \cdots x_{\tau_n(x)-1}) \geq 0.$$

Lastly, we must show that $\Phi(x_0, \dots, x_{\tau_n(x)-1})/n \rightarrow \tilde{\varphi}_\infty$ almost everywhere,

$$\begin{aligned} \Phi(x_0, \dots, x_{\tau_n(x)-1}) - S_{\tau_n(x)}\varphi(x) &= \sup_{y \in [x_0 \cdots x_{k-1}]^+} (S_{\tau_n(x)}\varphi(y) - S_{\tau_n(x)}\varphi(x)) \\ &\leq \sum_{j=0}^{\tau_n(x)-1} V_j(\varphi). \end{aligned}$$

By Lemma 6.2, for λ_R -a.e. $x \in R$, we have

$$\varliminf_{n \rightarrow \infty} \frac{1}{n} (\Phi(x_0 \cdots x_{\tau_n(x)-1}) - S_{\tau_n(x)}\varphi(x)) = 0,$$

which means that $\Phi(x_0 \cdots x_{\tau_n(x)-1})/n \rightarrow \tilde{\varphi}_\infty$. We conclude that $h_{\lambda_R}(T) + \int \tilde{\varphi} d\lambda_R = J(x) + \tilde{\varphi}_\infty \geq 0$, so μ is an equilibrium measure. □

Acknowledgements. The authors were partially supported by NSF grants DMS-1554794 and DMS-2154378. V.C. was partially supported by a Simons Foundation Fellowship. We are grateful to the anonymous referee for a careful reading and for a number of helpful comments that improved the paper, especially in Theorem 2.2 and its proof.

A. Appendix. Pressure of factorial collections

We prove Lemma 2.4 following the argument in [CP19, §4.4]. First observe that the argument in equation (1.3) showing that $\Lambda_{m+n}(\mathcal{L}) \leq \Lambda_m(\mathcal{L})\Lambda_n(\mathcal{L})$ works equally well when \mathcal{L} is replaced by any factorial \mathcal{D} , and thus

$$\Lambda_{n+m}(\mathcal{D}) \leq \Lambda_n(\mathcal{D})\Lambda_m(\mathcal{D}). \tag{A.1}$$

Given this submultiplicativity, Fekete’s lemma implies that the following limit exists:

$$P(\mathcal{D}) := \lim_{n \rightarrow \infty} \frac{1}{n} \log \Lambda_n(\mathcal{D}) = \inf_{n \in \mathbb{N}} \frac{1}{n} \log \Lambda_n(\mathcal{D}). \tag{A.2}$$

This limit is finite whenever \mathcal{D} is non-empty; indeed, if A is the alphabet for the shift space, then $e^{-n\|\varphi\|} \leq \Lambda_n(\mathcal{D}) \leq e^{n\|\varphi\|} (\#A)^n$ for all n , which gives $-\|\varphi\| \leq P(\mathcal{D}) \leq \|\varphi\| + \log(\#A)$.

To prove Lemma 2.4, it suffices to prove that $P(X_{\mathcal{D}}, \varphi) \geq P(\mathcal{D})$, since the other inequality is immediate from the inclusion $\mathcal{L}(X_{\mathcal{D}}) \subset \mathcal{D}$. To this end, fix $\epsilon > 0$ and use equation (A.2) to get N_0 such that for all $n \geq N_0$, we have

$$e^{nP(\mathcal{D})} \leq \Lambda_n(\mathcal{D}) \leq e^{n(P(\mathcal{D})+\epsilon)}. \tag{A.3}$$

Given $j \in \mathbb{N}$, define

$$\mathcal{D}^{(j)} := \{w \in \mathcal{D} : \text{there exist } u, v \in \mathcal{D}_j \text{ such that } u w v \in \mathcal{D}\}. \tag{A.4}$$

For every $N, j \in \mathbb{N}$, we have $\mathcal{D}_{N+2j} \subset \mathcal{D}_j \mathcal{D}_N^{(j)} \mathcal{D}_j$; that is, every word $w \in \mathcal{D}_{N+2j}$ has the property that $w_{(j,j+N]} \in \mathcal{D}^{(j)}$. The same argument that gave equation (A.1) gives

$$\Lambda_{N+2j}(\mathcal{D}) \leq \Lambda_j(\mathcal{D})^2 \Lambda_N(\mathcal{D}^{(j)}). \tag{A.5}$$

Moreover, since $\mathcal{D}^{(j)}$ is factorial for each j , we can iterate equation (A.1) to obtain

$$\Lambda_{kn}(\mathcal{D}^{(j)}) \leq \Lambda_n(\mathcal{D}^{(j)})^k$$

for every $k, n, j \in \mathbb{N}$. Using equations (A.3) and (A.5) with $N = kn, j \geq N_0$, this gives

$$e^{(kn+2j)P(\mathcal{D})} \leq \Lambda_{kn+2j}(\mathcal{D}) \leq \Lambda_j(\mathcal{D})^2 \Lambda_{kn}(\mathcal{D}^{(j)}) \leq e^{2j(P(\mathcal{D})+\epsilon)} \Lambda_n(\mathcal{D}^{(j)})^k. \tag{A.6}$$

Dividing both sides by $e^{2jP(\mathcal{D})}$ gives

$$e^{knP(\mathcal{D})} \leq e^{2j\epsilon} \Lambda_n(\mathcal{D}^{(j)})^k,$$

at which point, we can take logs and divide by kn to get

$$P(\mathcal{D}) \leq \frac{2j}{kn}\epsilon + \frac{1}{n} \log \Lambda_n(\mathcal{D}^{(j)}).$$

Fixing $n \in \mathbb{N}$ and $j \geq N_0$, we can send $k \rightarrow \infty$ and obtain

$$P(\mathcal{D}) \leq \frac{1}{n} \log \Lambda_n(\mathcal{D}^{(j)}). \tag{A.7}$$

Observe that the sets $\mathcal{D}^{(j)}$ decrease monotonically to $\mathcal{L}(X_{\mathcal{D}})$: in particular, for every $n \in \mathbb{N}$, we have

$$\mathcal{D}_n = \mathcal{D}_n^{(0)} \supset \mathcal{D}_n^{(1)} \supset \mathcal{D}_n^{(2)} \supset \dots \supset \mathcal{L}_n(X_{\mathcal{D}}) \quad \text{and} \quad \mathcal{L}_n(X_{\mathcal{D}}) = \bigcap_{j \in \mathbb{N}} \mathcal{D}_n^{(j)}.$$

Since \mathcal{D}_n is finite, there is $j = j(n) \geq N_0$ such that $\mathcal{D}_n^{(j)} = \mathcal{L}_n(X_{\mathcal{D}})$, so equation (A.7) gives

$$P(\mathcal{D}) \leq \frac{1}{n} \log \Lambda_n(\mathcal{D}^{(j(n))}) = \frac{1}{n} \log \Lambda_n(X_{\mathcal{D}})$$

for all n . Sending $n \rightarrow \infty$ proves Lemma 2.4.

B. Appendix. Uniqueness with non-uniform specification

B.1. *Non-uniform specification for flows.* We will deduce Theorem 2.7 from [PYY22, Theorem A]. First, we need the following definitions from [CT16, PYY22]. Throughout, $(f_s)_{s \in \mathbb{R}}$ will denote a continuous flow on a compact metric space (M, d) .

Definition B.1. For $\epsilon > 0$ and $x \in M$, the *two-sided infinite Bowen ball* at x is

$$\Gamma_\epsilon(x) = \{y \in M : d(f_s(x), f_s(y)) \leq \epsilon \text{ for all } s \in \mathbb{R}\}.$$

A flow f_s is *expansive at scale ϵ* if there exists an $s_0 > 0$, such that $\Gamma_\epsilon(x) \subset f_{[-s_0, s_0]}(x)$ for every $x \in X$.

We identify a pair $(x, T) \in M \times [0, \infty)$ with the parameterized curve of the orbit segment starting at x flowing for time T under f_s . Thus, $M \times [0, \infty)$ represents the space of finite-length orbit segments.

Definition B.2. A *decomposition* $(\mathcal{P}, \mathcal{G}, \mathcal{S})$ for $M \times [0, \infty)$ consists of three collections $\mathcal{P}, \mathcal{G}, \mathcal{S} \subset M \times [0, \infty)$ and three functions $P, G, S: M \times [0, \infty) \rightarrow [0, \infty)$ such that for every $(x, T) \in M \times [0, \infty)$, the values $P(x, T)$, $G(x, T)$, and $S(x, T)$ satisfy $T = P(x, T) + G(x, T) + S(x, T)$, and

$$(x, P(x, T)) \in \mathcal{P}, \quad (f_{P(x, T)}(x), G(x, T)) \in \mathcal{G}, \quad (f_{P(x, T)+G(x, T)}(x), S(x, T)) \in \mathcal{S}.$$

As in Theorem 2.7, we will require \mathcal{G} to have specification and the Bowen property, and \mathcal{P}, \mathcal{S} to be small from the point of view of pressure. In this flow setting, these definitions take the following form.

Definition B.3. A collection of orbit segments $\mathcal{G} \subset M \times [0, \infty)$ has *specification* at scale δ if there exists $t > 0$ such that for every finite sequence $\{(x_i, T_i)\}_{i=1}^k \subset \mathcal{G}$, there exists a point y such that writing $s_j = \sum_{i=1}^{j-1} (T_i + t)$, we have

$$d_{T_j}(f_{s_j}(y), x_j) < \delta \quad \text{for every } 1 \leq j \leq k.$$

Given $(x, T) \in M \times [0, \infty)$ and $\epsilon > 0$, the *(closed) Bowen ball* of order T around x with radius ϵ is $\bar{B}_T(x, \epsilon) = \{y \in M : d(f_s(x), f_s(y)) \leq \epsilon \text{ for all } s \in [0, T]\}$. The remaining definitions involve a continuous potential $\hat{\phi}: M \rightarrow \mathbb{R}$. Define

$$\Phi_\epsilon(x, T) = \sup_{y \in \bar{B}_T(x, \epsilon)} \int_0^T \hat{\phi}(f_s(y)) \, ds.$$

For $\epsilon = 0$, we have $\Phi_0(x, T) = \int_0^T \hat{\phi}(f_s(x)) \, ds$.

Definition B.4. $\hat{\phi}$ has the *Bowen property at scale $\epsilon > 0$* on $\mathcal{G} \subset M \times [0, \infty)$ if there exists $K > 0$ such that

$$\sup\{|\Phi_0(x, T) - \Phi_0(y, T)| : (x, T) \in \mathcal{G}, y \in \bar{B}_T(x, \epsilon)\} \leq K.$$

The prefix and suffix collections \mathcal{P}, \mathcal{S} are required to be small in the sense of pressure.

Definition B.5. For $\mathcal{C} \subset M \times [0, \infty)$, let $\mathcal{C}_T = \{x \in M : (x, T) \in \mathcal{C}\}$, and define

$$\Lambda(\mathcal{C}, \hat{\phi}, \delta, \epsilon, T) = \sup \left\{ \sum_{x \in E} e^{\Phi_\epsilon(x, T)} : E \subset \mathcal{C}_T \text{ is } (T, \delta)\text{-separated} \right\}.$$

The pressure of \mathcal{C} at scales δ, ϵ is

$$P(\mathcal{C}, \hat{\phi}, \delta, \epsilon) = \overline{\lim}_{T \rightarrow \infty} \frac{1}{T} \log(\Lambda(\mathcal{C}, \hat{\phi}, \delta, \epsilon, T)).$$

Since T takes continuous values, care must be exercised in applying Definition B.5 in a situation where removing short pieces from the beginning and end of an orbit segment in \mathcal{C} could produce an orbit segment not in \mathcal{C} ; one could have many orbit segments in \mathcal{C} with similar but not identical values of T , and Definition B.5 would never see all of them at once. Thus, we make one final definition: let

$$[\mathcal{C}] = \{(x, n) \in M \times \mathbb{N} : (f_{-a}(x), n + a + b) \in \mathcal{C} \text{ for some } a, b \in [0, 1]\}$$

be the collection of integer-length orbit segments that are obtained by removing pieces of length ≤ 1 from the ends of elements of \mathcal{C} .

Now we can state a general result for flows, which is an immediate consequence of [PYY22, Theorem A, equation (3.2), and Lemma 6.6]. (The result in [PYY22] uses a non-uniform expansivity assumption which is more complicated to define. The uniform expansivity assumption is satisfied in our application and implies the condition there. Additionally, [PYY22] requires ‘tail (W)-specification’, which follows from Definition B.3.)

THEOREM B.6. *Let $(f_s)_{s \in \mathbb{R}}$ be a continuous flow on a compact metric space M , and $\hat{\phi}: M \rightarrow \mathbb{R}$ a continuous potential function. Suppose there exist $\epsilon, \delta > 0$ with $\epsilon \geq 2000\delta$ such that the flow is expansive at scale ϵ , and it admits a decomposition $(\mathcal{P}, \mathcal{G}, \mathcal{S})$ of orbit segments with the following properties:*

- (1) \mathcal{G} has specification at scale δ ;
- (2) ϕ has the Bowen property at scale ϵ on \mathcal{G} ;
- (3) $P([\mathcal{P}] \cup [\mathcal{S}], \hat{\phi}, \delta, \epsilon) < P(\hat{\phi})$.

Then there exists a unique equilibrium measure for the potential $\hat{\phi}$, and for every $\gamma \in [8\delta, 200\delta]$, we have $\overline{\lim}_{T \rightarrow \infty} \Lambda(M \times [0, \infty), \hat{\phi}, 2\gamma, 2\gamma, T)e^{-TP(\hat{\phi})} < \infty$.

B.2. A suspension flow. The strategy we use to obtain Theorem 2.7 from Theorem B.6 is to compare the shift space X to a suspension flow over X . Let $\hat{X} = X \times \mathbb{R}/\sim$, where we quotient by the equivalence relation $(x, a + n) \sim (\sigma^n x, a)$ for all $x \in X, a \in \mathbb{R}$, and $n \in \mathbb{Z}$. Observe that we also have $\hat{X} = X \times [0, 1]/\sim$. We will routinely write (x, a) as a shorthand for its equivalence class.

Let $f_s: \hat{X} \rightarrow \hat{X}$ be the suspension flow over X with a constant roof function of 1; that is, the quotient of the vertical flow on $X \times \mathbb{R}$. Fix $\theta = 1/2000, \epsilon \in (\theta^2, \theta)$, and $\delta = \epsilon\theta$, so the relation between ϵ and δ in Theorem B.6 is satisfied. Equip the shift space X with the metric

$$d(x, y) := \theta^n \quad \text{where } n = \min\{|m| : x_m \neq y_m\},$$

and define a metric \hat{d} on \hat{X} following the procedure in [BW72, §4], so that for all $x, y \in X$ and $a \in [0, 1]$, we have

$$\hat{d}((x, a), (y, a)) \leq ad(\sigma x, \sigma y) + (1 - a)d(x, y), \tag{B.1}$$

$$\hat{d}((x, \frac{1}{2}), (y, a)) \geq \min(d(x, y), d(\sigma x, \sigma y)). \tag{B.2}$$

LEMMA B.7. *If $\hat{d}((x, \frac{1}{2}), (y, a)) \leq \epsilon$, then $x_0 = y_0$ and $x_1 = y_1$.*

Proof. If $\hat{d}((x, \frac{1}{2}), (y, a)) \leq \epsilon < \theta$, then equation (B.2) implies that either $d(x, y) < \theta$ or $d(\sigma x, \sigma y) < \theta$. In the first case, we have $x_{-1}x_0x_1 = y_{-1}y_0y_1$; in the second case, we have $x_0x_1x_2 = y_0y_1y_2$. □

A direct consequence of Lemma B.7 is that the suspension flow is expansive at scale ϵ . Indeed, if $(y, b) \in \Gamma_\epsilon((x, a))$, then without loss of generality, we can assume that (y, b) is the element if its equivalence class with $|b - a| \leq \frac{1}{2}$, and applying $f_{n+\frac{1}{2}-a}$ to both (y, b) and (x, a) for every $n \in \mathbb{Z}$, Lemma B.7 gives $x = y$.

LEMMA B.8. *If $x, y \in X$ and $n \in \mathbb{N}$ are such that $x_k = y_k$ for all $-2 \leq k \leq n + 2$, then $(y, 0) \in B_n((x, 0), \xi)$ for each $\xi > \theta^3$.*

Proof. If $\hat{d}((x, a), (y, a)) \geq \xi > \theta^3$, then either $d(x, y) > \theta^3$ or $d(\sigma x, \sigma y) > \theta^3$, which in turn implies that $x_k \neq y_k$ for some $k \in \{-2, -1, 0, 1, 2, 3\}$. Applying this to $(\sigma^j x, a)$ and $(\sigma^j y, a)$ for all $0 \leq j < n$ and $a \in [0, 1]$ gives the result. □

Given a continuous $\varphi : X \rightarrow \mathbb{R}$, we define $\hat{\varphi} : \hat{X} \rightarrow \mathbb{R}$ by

$$\hat{\varphi}(x, a) = a\varphi(\sigma x) + (1 - a)\varphi(x).$$

This choice of $\hat{\varphi}$ leads to the following property.

LEMMA B.9. *Given any $x \in X$ and $n \in \mathbb{N}$, we have*

$$|\Phi_0((x, 0), n) - S_n\varphi(x)| \leq \|\varphi\|.$$

Proof. Observe that $\int_0^1 \hat{\varphi}(x, a) da = \varphi(x) + \frac{1}{2}(\varphi(\sigma x) - \varphi(x))$, so

$$\begin{aligned} \int_0^n \hat{\varphi}(f_s(x, 0)) ds &= \sum_{k=0}^{n-1} \varphi(\sigma^k x) + \frac{1}{2}(\varphi(\sigma^{k+1} x) - \varphi(\sigma^k x)) \\ &= S_n\varphi(x) + \frac{1}{2}(\varphi(\sigma^n x) - \varphi(x)), \end{aligned} \tag{B.3}$$

which proves the lemma. □

There is a natural bijection between shift-invariant probability measures μ on X and flow-invariant probability measures $\hat{\mu}$ on \hat{X} , obtained by taking the product of μ with Lebesgue measure on $[0, 1]$. This bijection preserves entropy and has the property that $\int \varphi d\mu = \int \hat{\varphi} d\hat{\mu}$. From the variational principle, we conclude that $P(X, \varphi) = P(\hat{X}, \hat{\varphi})$, and that μ is an equilibrium measure for (X, σ, φ) if and only if $\hat{\mu}$ is an equilibrium measure for $(\hat{X}, (f_s), \hat{\varphi})$. In particular, the uniqueness conclusion in Theorem B.6 implies the uniqueness conclusion of Theorem 2.7. The fact that the upper bound in Theorem B.6 implies $\overline{Q} < \infty$ in Theorem 2.7 is a consequence of the following lemma.

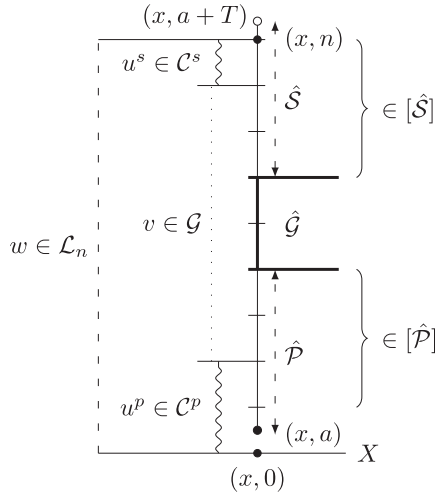

FIGURE 2. Decomposing $((x, a), T)$. Tick marks along the vertical line above $(x, 0)$ indicate integers.

LEMMA B.10. *Given $\gamma \in [8\delta, 200\delta]$, we have*

$$\Lambda_n(X) \leq e^{10\|\varphi\|} \Lambda(M \times [0, \infty), \hat{\varphi}, 2\gamma, 2\gamma, n - 1).$$

Proof. For each $w \in \mathcal{L}_n$, choose $x_w \in [w]^+$, and consider the set $E = \{(x_w, 0) : w \in \mathcal{L}_n\}$. Observe that if $x, y \in X$ are such that $(y, 0) \in B_{n-1}((x, 0), 2\gamma)$, then we have $\hat{d}((\sigma^k x, \frac{1}{2}), (\sigma^k y, \frac{1}{2})) < 2\gamma < \epsilon$ for all $0 \leq k < n - 1$, and by Lemma B.7, this gives $x_{[0,n]} = y_{[0,n]}$. Thus, E is $(n - 1, 2\gamma)$ -separated for the flow. Moreover, for every $w \in \mathcal{L}_n$ and $y \in [w]^+$, we have $(y, 2) \in B_{n-5}((x, 2), \delta)$ by Lemma B.8, so

$$\begin{aligned} S_n \varphi(y) &\leq 5\|\varphi\| + S_{n-5} \varphi(\sigma^2 y) \leq 6\|\varphi\| + \Phi_\delta((x, 2), n - 5) \\ &\leq 10\|\varphi\| + \Phi_{2\gamma}((x, 0), n - 1), \end{aligned}$$

where the second inequality uses Lemma B.9. Taking a supremum over $y \in [w]^+$ gives $\Phi(w) \leq 10\|\varphi\| + \Phi_{2\gamma}((x, 0), n - 1)$. Summing over w proves the lemma. \square

To deduce Theorem 2.7 from Theorem B.6, it remains to show that if X and φ satisfy the conditions of Theorem 2.7, then \hat{X} and $\hat{\varphi}$ satisfy the conditions of Theorem B.6. Note that expansivity of the suspension flow was proved above via Lemma B.7. We address the remaining conditions in the next section.

B.3. Non-uniform specification for the suspension flow

B.3.1. *A decomposition.* The hypothesis of Theorem 2.7 provides a decomposition $\mathcal{C}^p, \mathcal{G}, \mathcal{C}^s$ of the language \mathcal{L} of the shift space X ; Figure 2 illustrates a corresponding decomposition of orbit segments for the suspension flow.

Recall that $((x, a), T)$ represents the orbit segment of length T starting at $(x, a) \in \hat{X}$. The collections of orbit segments illustrated in Figure 2 are

$$\begin{aligned} \hat{\mathcal{P}} &= \{((x, a), k + r) : k \in \mathbb{N}, a \in [0, 1), x_0 \cdots x_{k-1} \in \mathcal{C}^p, \text{ and } r \in [0, 2]\}, \\ \hat{\mathcal{G}} &= \{((x, 0), n) : n \in \mathbb{N} \text{ and } x_{-2}x_{-1}x_0 \cdots x_n x_{n+1}x_{n+2} \in \mathcal{G}\}, \\ \hat{\mathcal{S}} &= \{((x, 0), k + r) : k \in \mathbb{N}, x_j \cdots x_{k-1} \in \mathcal{C}^s \text{ for some } j \in \{0, 1, 2\}, \text{ and } r \in [0, 1)\}. \end{aligned}$$

To decompose $((x, a), T) \in \hat{X} \times [0, \infty)$ with $a \in [0, 1)$, let $n = \lfloor a + T \rfloor$ and consider the word $w = x_0x_1 \cdots x_{n-1} \in \mathcal{L}$. Let $w = u^p v u^s$, where $u^p \in \mathcal{C}^p$, $v \in \mathcal{G}$, and $u^s \in \mathcal{C}^s$.

Informally, the decomposition of $((x, a), T)$ is given by removing two symbols from either end of $v \in \mathcal{G}$ and calling the resulting orbit segment the $\hat{\mathcal{G}}$ -part of $((x, a), T)$, then observing that the parts of $((x, a), T)$ that lie before and after this piece are in $\hat{\mathcal{P}}$ and $\hat{\mathcal{S}}$, respectively. More precisely, there are two cases to consider.

- If $|v| \geq 4$, then let $P = |u^p| + 2 - a$, $G = |v| - 4$, and $S = |u^s| + 2 + a + T - n$.
- If $|v| < 4$, then let $k = \lfloor |v|/2 \rfloor$ and put $P = |u^p| + k - a$; similarly, put $\ell = \lceil |v|/2 \rceil$ and $S = |u^s| + \ell + a + T - n$. In this case, $G = 0$.

In both cases, one obtains $((x, a), P) \in \hat{\mathcal{P}}$, $(f_P(x, a), G) \in \hat{\mathcal{G}}$, and $(f_{P+G}(x, a), S) \in \hat{\mathcal{S}}$.

B.3.2. Specification. We prove that $\hat{\mathcal{G}}$ has specification at scale δ . By condition (I) of Theorem 2.7, there is $t \in \mathbb{N}$ such that for any collection of words $w^1, \dots, w^k \in \mathcal{G}$, there are words $u^1, \dots, u^{k-1} \in \mathcal{L}_t$ such that $w^1 u^1 w^2 \cdots w^{k-1} u^{k-1} w^k \in \mathcal{L}$.

Given any collection of orbit segments $((x_i, 0), n_i) \in \hat{\mathcal{G}}$ for $1 \leq i \leq k$, let $w^i = (x_i)_{[-2n_i+2]}$, so that $w^i \in \mathcal{G}$. Let $u^1, \dots, u^{k-1} \in \mathcal{L}_t$ be the words provided by condition (I), so that $w^1 u^1 w^2 \cdots w^{k-1} u^{k-1} w^k \in \mathcal{L}$; then fix $y \in [w^1 u^1 w^2 \cdots u^{k-1} w^k]$ and observe that $(\sigma^2 y, 0)$ has the desired shadowing property by Lemma B.8, with gap size $t + 4$.

B.3.3. Bowen property. Fix $((x, 0), n) \in \hat{\mathcal{G}}$ and $(y, a) \in \bar{B}_n((x, 0), \epsilon)$, where $x, y \in X$ and $|a| \leq \frac{1}{2}$. For each $k = 0, 1, 2, \dots, n - 1$, we have $\hat{d}((\sigma^k x, \frac{1}{2}), (\sigma^k y, a + \frac{1}{2})) \leq \epsilon$, and so Lemma B.7 gives $x_0 x_1 \cdots x_n = y_0 y_1 \cdots y_n$.

Observe that $|\Phi_0((y, a), n) - \Phi_0((y, 0), n)| \leq 2a\|\varphi\| \leq \|\varphi\|$. By Lemma B.9,

$$|\Phi_0((x, 0), n) - \Phi_0((y, 0), n)| \leq |S_n \varphi(x) - S_n \varphi(y)| + 2\|\varphi\|.$$

We conclude that

$$|\Phi_0((y, a), n) - \Phi_0((x, 0), n)| \leq |S_n \varphi(x) - S_n \varphi(y)| + 3\|\varphi\|. \tag{B.4}$$

Since $((x, 0), n) \in \hat{\mathcal{G}}$, we have $x_{-2}x_{-1} \cdots x_n x_{n+1}x_{n+2} \in \mathcal{G}$. Using equation (B.4), we get

$$|\Phi_0((y, a), n) - \Phi_0((x, 0), n)| \leq |S_{n+4} \varphi(\sigma^{-2}x) - S_{n+4} \varphi(\sigma^{-2}y)| + 11\|\varphi\|$$

and now condition (II) (the Bowen property on \mathcal{G}) gives

$$|\Phi_0((y, a), n) - \Phi_0((x, 0), n)| \leq C + 11\|\varphi\|,$$

which proves that $\hat{\varphi}$ has the Bowen property on $\hat{\mathcal{G}}$ at scale ϵ .

B.3.4. Pressure gap. We prove the pressure gap condition by way of the following lemma.

LEMMA B.11. $P([\hat{S}], \hat{\varphi}, \delta, \epsilon) \leq P(\mathcal{C}^s, \varphi)$ and $P([\hat{\mathcal{P}}], \hat{\varphi}, \delta, \epsilon) \leq P(\mathcal{C}^p, \varphi)$.

Given Lemma B.11, we have $P([\hat{\mathcal{P}}] \cup [\hat{S}], \hat{\varphi}, \delta\epsilon) \leq P(\mathcal{C}^p \cup \mathcal{C}^s, \varphi) < P(\varphi) = P(\hat{\varphi})$, where the second inequality is condition (III) of Theorem 2.7. The rest of this section is devoted to the proof of Lemma B.11 for $[\hat{S}]$; the proof for $[\hat{\mathcal{P}}]$ is similar.

Given $((x, a), n) \in [\hat{S}]$ with $a \in [0, 1]$, we have $u := x_j \cdots x_{k-1} \in \mathcal{C}^s$ for some $j \in \{0, 1, 2\}$ and $k \in \{n, n + 1\}$. If $(y, b) \in B_n((x, a), \epsilon)$ and $|b - a| \leq \frac{1}{2}$, then $(\sigma y, b - a) \in B_{n-1}((\sigma x, 0), \epsilon)$, and arguing as in §B.3.3 gives $y_{[1,n]} = x_{[1,n]}$. Moreover, $b \in [-\frac{1}{2}, \frac{3}{2}]$, so using Lemma B.9, we get

$$\Phi_0((y, b), n) \leq 3\|\varphi\| + \Phi_0((y, 0), n) \leq 4\|\varphi\| + S_n\varphi(y). \tag{B.5}$$

Since $S_n\varphi(y) + S_{k-n}\varphi(\sigma^n y) = S_j\varphi(y) + S_{k-j}\varphi(\sigma^j y)$, we have

$$|S_n\varphi(y) - S_{k-j}\varphi(\sigma^j y)| \leq (j + (k - n))\|\varphi\| \leq 3\|\varphi\|,$$

and with $V_n = V_n(\varphi)$ as in §1.4, we can write $A_N := \sum_{i=0}^{N-1} V_i = o(N)$ and obtain

$$|S_{k-j}\varphi(\sigma^j y) - S_{k-j}\varphi(\sigma^j x)| \leq \sum_{i=0}^{k-j-1} V_{\min(1+i, k-j-i)} \leq 2A_{k-j}.$$

Combining these gives

$$S_n\varphi(y) \leq S_{k-j}\varphi(\sigma^j x) + 3\|\varphi\| + 2A_{k-j} \leq \Phi(u) + 3\|\varphi\| + 2A_{n+1},$$

and together with equation (B.5), we obtain

$$\Phi_\epsilon((x, a), n) \leq 7\|\varphi\| + \Phi(u) + 2A_{n+1}. \tag{B.6}$$

This will let us bound the partition sum associated to an (n, δ) -separated set $E \subset \hat{X}$ once we control the multiplicity of the map $((x, a), n) \mapsto u$.

LEMMA B.12. *There exists $D > 0$ such that given any $n \in \mathbb{N}$ and any (n, δ) -separated set $E \subset \hat{X}$, we have $\#\{(x, a) \in E : a \in [0, 1], x_{[j,k]} = u\} \leq D$ for each $j \in \{0, 1, 2\}$ and $k \in \{n, n + 1\}$.*

Proof. Fix $\xi \in (\theta^3, \delta)$. If $(x, a), (y, b) \in E$ are distinct and have $x_{[-2, n+3]} = y_{[-2, n+3]}$, then Lemma B.8 gives $(y, 0) \in B_{n+1}((x, 0), \xi)$, and thus $(y, b) \in B_n((x, a), \xi + |b - a|)$; this implies $\xi + |b - a| \geq \delta$, so $|b - a| \geq \delta - \xi$. It follows that E can contain at most $1/(\delta - \xi)$ points for each choice of the symbols in positions $-2, -1, \dots, n + 3$. Given j, k , if $x_{[j,k]} = u = y_{[j,k]}$, then the only symbols where we could possibly have $x_i \neq y_i$ occur when $i \in \{-2, -1, 0, 1, n + 1, n + 2, n + 3\}$. There are at most $(\#A)^7$ ways of filling these symbols, which proves the lemma with $D = (\#A)^7/(\delta - \xi)$. \square

Using Lemma B.12 and equation (B.6) gives

$$\Lambda([\hat{S}], \hat{\varphi}, \delta, \epsilon, n) \leq \sum_{j=0}^2 \sum_{k=n}^{n+1} D e^{7\|\varphi\| + 2A_{n+1}} \Lambda_{k-j}(\mathcal{C}^s),$$

and since $A_{n+1} = o(n)$, this proves Lemma B.11.

REFERENCES

- [BD20] V. Baladi and M. F. Demers. On the measure of maximal entropy for finite horizon Sinai billiard maps. *J. Amer. Math. Soc.* **33**(2) (2020), 381–449.
- [Ber88] A. Bertrand. Specification, synchronisation, average length. *Coding Theory and Applications (Cachan, 1986) (Lecture Notes in Computer Science, 311)*. Ed. G. Cohen and P. Godlewski. Springer, Berlin, 1988, pp. 86–95.
- [BO23] S. Ben Ovadia. Invariant family of leaf measures and the Ledrappier–Young property for hyperbolic equilibrium states. *Ergod. Th. & Dynam. Sys.* **43**(11) (2023), 3603–3635.
- [Bow73] R. Bowen. Topological entropy for noncompact sets. *Trans. Amer. Math. Soc.* **184** (1973), 125–136.
- [Bow75] R. Bowen. Some systems with unique equilibrium states. *Math. Systems Theory* **8**(3) (1974/75), 193–202.
- [Bow08] R. Bowen. *Equilibrium States and the Ergodic Theory of Anosov Diffeomorphisms (Lecture Notes in Mathematics, 470)*, revised edn. Ed. J.-R. Chazottes. Springer-Verlag, Berlin, 2008; with a preface by D. Ruelle.
- [BW72] R. Bowen and P. Walters. Expansive one-parameter flows. *J. Differential Equations* **12** (1972), 180–193.
- [Cal22] B. Call. The K-property for some unique equilibrium states in flows and homeomorphisms. *Ergod. Th. & Dynam. Sys.* **42**(8) (2022), 2509–2532.
- [CD24] V. Climenhaga and J. Day. Leaf measures and entropy for dispersing billiards. Manuscript in preparation.
- [Cli18] V. Climenhaga. Specification and towers in shift spaces. *Comm. Math. Phys.* **364**(2) (2018), 441–504.
- [Cli22] V. Climenhaga. An improved non-uniform specification result. *Blog post*, 2022. <https://vaughnclimenhaga.wordpress.com/2022/06/06/an-improved-non-uniform-specification-result/>.
- [Cli24] V. Climenhaga, SRB and equilibrium measures via dimension theory. *A Vision for Dynamics in the 21st Century—The Legacy of Anatole Katok*. Ed. D. Damjanovic, B. Hasselblatt, A. Gogolev and Y. Pesin. Cambridge University Press, Cambridge, 2024, pp. 94–138.
- [CP19] V. Climenhaga and R. Pavlov. One-sided almost specification and intrinsic ergodicity. *Ergod. Th. & Dynam. Sys.* **39**(9) (2019), 2456–2480.
- [CPZ19] V. Climenhaga, Y. Pesin and A. Zelerowicz. Equilibrium states in dynamical systems via geometric measure theory. *Bull. Amer. Math. Soc. (N.S.)* **56**(4) (2019), 569–610.
- [CPZ20] V. Climenhaga, Y. Pesin and A. Zelerowicz. Equilibrium measures for some partially hyperbolic systems. *J. Mod. Dyn.* **16** (2020), 155–205.
- [CT13] V. Climenhaga and D. J. Thompson. Equilibrium states beyond specification and the Bowen property. *J. Lond. Math. Soc. (2)* **87**(2) (2013), 401–427.
- [CT16] V. Climenhaga and D. J. Thompson. Unique equilibrium states for flows and homeomorphisms with non-uniform structure. *Adv. Math.* **303** (2016), 745–799.
- [Gla03] E. Glasner. *Ergodic Theory via Joinings (Mathematical Surveys and Monographs, 101)*. American Mathematical Society, Providence, RI, 2003.
- [Ham89] U. Hamenstädt. A new description of the Bowen–Margulis measure. *Ergod. Th. & Dynam. Sys.* **9**(3) (1989), 455–464.
- [Has89] B. Hasselblatt. A new construction of the Margulis measure for Anosov flows. *Ergod. Th. & Dynam. Sys.* **9**(3) (1989), 465–468.
- [Hay94] N. T. A. Haydn. Canonical product structure of equilibrium states. *Random Comput. Dyn.* **2**(1) (1994), 79–96.
- [Led77] F. Ledrappier. Mesures d'équilibre d'entropie complètement positive. *Dynamical Systems, Vol. II—Warsaw (Astérisque, 50)*. Société Mathématique de France, Paris, 1977, pp. 251–272.
- [Lep00] R. Leplaideur. Local product structure for equilibrium states. *Trans. Amer. Math. Soc.* **352**(4) (2000), 1889–1912.
- [Mar70] G. A. Margulis. Certain measures that are connected with U -flows on compact manifolds. *Funkcional. Anal. i Priložen.* **4**(1) (1970), 62–76.
- [PP84] Y. B. Pesin and B. S. Pitskel'. Topological pressure and the variational principle for noncompact sets. *Funkcional. Anal. i Priložen.* **18**(4) (1984), 50–63, 96.
- [PYY22] M. J. Pacifico, F. Yang and J. Yang. Existence and uniqueness of equilibrium states for systems with specification at a fixed scale: an improved Climenhaga–Thompson criterion. *Nonlinearity* **35**(12) (2022), 5963–5992.
- [Wal78] P. Walters. Invariant measures and equilibrium states for some mappings which expand distances. *Trans. Amer. Math. Soc.* **236** (1978), 121–153.
- [Wal82] P. Walters. *An Introduction to Ergodic Theory (Graduate Texts in Mathematics, 79)*. Springer-Verlag, New York, 1982.