

Modeling hole size, lifetime and fuel consumption in hot-water ice drilling

L. GREENLER,¹ T. BENSON,¹ J. CHERWINKA,¹ A. ELCHEIKH,² F. FEYZI,³
A. KARLE,⁴ R. PAULOS¹

¹Physical Sciences Laboratory, University of Wisconsin–Madison, Stoughton, WI, USA
E-mail: greenler@psl.wisc.edu

²Australian Antarctic Division, Kingston, Tasmania, Australia

³Facility for Rare Isotope Beams, Michigan State University, East Lansing, MI, USA

⁴Wisconsin IceCube Particle Astrophysics Center, University of Wisconsin–Madison, Madison, WI, USA

ABSTRACT. IceCube, a cubic-kilometer neutrino detector, was built at the South Pole using a hot-water drill system. Deep holes were drilled into the Antarctic ice sheet and filled with highly sensitive optical instrumentation. For the hot-water drilling, a computer model was developed to predict the hole sizes and hole lifetimes during construction. The goal was to predict ultimate size and freezeback rates based on water flow rate and temperature, drill speed, ice temperature and ream parameters (for a secondary operation where hot water continues to flow as the drill is withdrawn). This model proved to be very successful. It increased confidence that the holes would remain open long enough after drilling to allow the deployment of the necessary instrumentation. It also allowed for a decrease, over the course of the project, in the amount of overdrilling that was used as a margin against a too-rapid freeze-in. This resulted in significant fuel savings.

KEYWORDS: glaciological instruments and methods, ice physics

INTRODUCTION

The IceCube project has built a ‘neutrino telescope’ at the South Pole. It gathers information from neutrinos, abundant subatomic particles that stream from astrophysical sources and travel unimpeded through the Earth to the South Pole. This detector consists of 5160 optical sensors attached to 86 cables, or strings, oriented vertically in the ice cap. The strings are 2400 m long, so their deployment required drilling 86 holes, each slightly over 2400 m deep. The holes are situated in a grid and spaced 125 m apart, yielding a distribution of optical sensors in $\sim 1 \text{ km}^3$ of ice. The large volume of instrumented ice increases the sensitivity of the detector.

The holes were made with a hot-water ‘drill’ consisting of an instrumented nozzle on the end of a continuous hose $\sim 2500 \text{ m}$ in length (Benson and others, 2014). The drill system is a closed-loop system consisting of >400 input/output sensors. The drill melts its way through the ice as 80°C water is pumped through the nozzle (the water is initially heated to a higher temperature but cools as it travels through the hose). During drilling, cooled water, at $1\text{--}2^\circ\text{C}$, is pumped out of the top of the hole and recycled through the heaters. With water only pumped out at the top of the hole, the hole remains full of water. After full depth is reached, a string of 60 glass spheres, containing instrumentation, is deployed into the water-filled hole. These spheres, or digital optical modules (DOMs), contain the instrumentation for the experiment. Over the following week or so, the hole completely freezes around the DOMs.

The drilling process consists of a drill phase (the drill melts its way down through the ice) followed by a ream phase (the drill is raised while the hot water continues to flow). The ream enlarges the hole and also keeps warm water in contact with the hole so that more heat is conducted into the ice. The more heat that is absorbed in

the ice surrounding the hole, the longer it takes for the hole to freeze shut. This was important as adequate time was needed, after drilling the hole, to lower the 2400 m long string of DOMs into the hole before it froze back too far. Thus, the design requirement was a hole diameter sufficient to accommodate a DOM, at $\sim 36 \text{ cm}$, plus freezeback space. The target determined for this project was to maintain a diameter of $>45 \text{ cm}$ for $\sim 1\text{--}1.5$ days after drilling.

There were several challenges to this project. The holes needed to be $\sim 2500 \text{ m}$ deep and larger in diameter than many previous hot-water-drilled holes. Also, the logistics of getting people and equipment to the South Pole is complicated. Finally, getting fuel to the Pole is expensive; conserving this fuel was vital.

This last concern was the impetus for the work in this paper. There is a trade-off between fuel conservation and the risk of inadequately sized holes. To conserve fuel, it was desirable to have a minimally sized hole, which would then freeze back shortly after the string of DOMs was lowered into place. However, if the hole was slightly *too* small, such that a string of instruments became stuck part way down, not only would the hole be lost, but the string of instruments would potentially be lost as well. The cost of this loss, for even a single hole, would be much greater than the cost of slightly overdrilling all the holes. It became clear that it was critical to have a good understanding of how the drilling parameters (water temperature, flow rate and drill speed) related to the size of the hole produced and to how quickly it froze shut.

The focus of this paper is a description of the heat transfer calculations that affected drilling rates for the ‘Enhanced Hot Water Drill’ of the IceCube project. The calculations are discussed in terms specific to that project. However, the equations and methods used are general and are applicable to other ice holes drilled in this manner.

OVERVIEW

This paper will look first at the simpler problem of melting ice with a hot-water drill, neglecting heat that is lost through conduction into the ice, then later examine a method of including that heat in the calculations.

Parameters and variables

The physical properties of ice are assumed not to vary significantly over the range of temperatures and pressures involved in this work. The same is assumed for the physical properties of water – except for viscosity and the Prandtl number, which are strongly temperature-dependent. (The Prandtl number is a dimensionless number that relates the relative rates of momentum and heat diffusion in a flowing fluid. It is important in calculating heat transfer from the water to the ice.) The density of water varies somewhat with temperature and pressure but not enough to significantly affect the calculations; the value chosen is the density at $\sim 60^\circ\text{C}$ – the average of the density of the 88°C supply water and the water density at 0°C .

The following lists give general and project-specific parameters, with corresponding values, along with variables that are used.

General parameters:

ρ_i	Density of ice (917 kg m^{-3})
ρ_w	Density of water (982 kg m^{-3})
Δ_{melt}	Ratio of specific volume of water to that of ice (0.93, dimensionless)
c_i	Specific heat of ice ($1950 \text{ J kg}^{-1} \text{ }^\circ\text{C}^{-1}$)
c_w	Specific heat of water ($4170 \text{ J kg}^{-1} \text{ }^\circ\text{C}^{-1}$)
c_f	Heat of fusion of ice ($335\,000 \text{ J kg}^{-1}$)
μ	Dynamic viscosity of water (function of temperature, $\text{kg m}^{-1} \text{ s}^{-1}$)
k_{ice}	Thermal conductivity of ice ($2.2 \text{ W m}^{-1} \text{ }^\circ\text{C}^{-1}$)
T_∞	Far-field temperature of ice (function of depth, -50°C at the surface, warmer with increasing ice depth)

Project-specific parameters:

\dot{V}	Water flow rate through drill ($1.262 \times 10^{-2} \text{ m}^3 \text{ s}^{-1}$, $\sim 200 \text{ gal min}^{-1}$)
r_{core}	Outer radius of the hose and most of the drill body (0.048 m)
k_{hose}	Thermal conductivity of hose wall material ($0.26 \text{ W m}^{-1} \text{ }^\circ\text{C}^{-1}$, estimated from material properties and checked with heat-loss measurements)

Variables:

A	Cross-sectional area of the flow region between the hose and hole wall (m^2)
D_h	Hydraulic diameter (m)
r	Radial position of a point in the ice (m)
t	Time (s)
R	Radius of hole (m)
Y	Distance above drill tip (m)
v	Drill advance speed (m s^{-1})
h	Convective heat transfer coefficient ($\text{W m}^{-2} \text{ }^\circ\text{C}^{-1}$)
T_w	Bulk water temperature in hole ($^\circ\text{C}$)
T	Ice temperature ($^\circ\text{C}$)
\dot{Q}	Heat rate (W)
\dot{Q}_{hose}	Rate of heat transfer through hose (W m^{-1})
Re	Reynolds number (dimensionless)
Pr	Prandtl number (dimensionless)

T_{tip} Temperature of water exiting drill tip (function of depth due to immersion of hose in varying depth of water in the hole)

VERTICAL HOLE TEMPERATURE PROFILE, HOLE SHAPE AND DRILLING RATE – NEGLECTING HEAT CONDUCTION INTO THE ICE

Ignoring heat conduction losses into the ice greatly simplifies the calculations. Heat conduction losses can be considered low at any point in the hole where most of the injected heat resides in the water that fills the hole rather than in the surrounding ice. Heat must, of course, conduct into the ice to warm it from its initial subzero temperature to the melting point, but when this occurs in a small zone near the hole wall it is negligible.

For this case, a closed-form solution can be developed (in terms of drill speed, water flow rate and water temperature) for maximum diameter of the hole and water temperature as a function of hole radius at a given depth. The derivation that follows is similar to that given by Humphrey and Echelmeyer (1990).

During drilling, the hole near the nozzle tip grows quickly, and there is not enough time for significant heat to be conducted into the ice before that ice is melted. In this region, it is reasonable to ignore heat conduction losses into the ice; the amount of heat that has warmed ice around the hole above the far-field temperature is negligible.

It is also convenient to do the calculation ignoring heat conduction into the ice as a check on the results of a more complete analysis. The water temperature predicted by these equations, for a set of conditions, is an upper bound. Any calculation that includes heat losses to the ice should predict a lower water temperature for a given radius hole due to this lost energy.

Methods neglecting heat conduction into the ice are completely inapplicable to freezeback calculations since freezeback is entirely due to heat conduction into the ice.

Water temperature as a function of hole radius

An energy balance on a control volume attached to the drill shows that the temperature of the water in the hole above the tip is a function of the radius of the hole. This temperature is designated $T_w(R)$. It is important to note that $T_w(R)$ is *not* the water temperature as a function of distance from the center of the hole but is, instead, the bulk water temperature in the hole *as a function of the size of the hole at that point*.

Consider a control volume that is attached to, and moves with, the drill (Fig. 1). The upper surface of the control volume is a horizontal circular area, the same diameter as the hole, at some height where the hole has radius R . The side of the volume is a vertical cylinder of radius R extending downward from the horizontal disk. The bottom is another disk, again of radius R , that closes the volume below the drill where the ice is at the far-field temperature. After the drill has been drilling for some time, it will reach a 'steady state' where the temperature and flow of the water and the shape of the hole, *in this control volume attached to the drill*, will not vary with time. In this steady-state condition, the energy in the control volume remains constant so that the sum of the energy streams entering and leaving is zero. There are three terms in this sum (J s^{-1}):

1. The heat input rate from water entering through hose, relative to 0°C:

$$\dot{V}\rho_w c_w T_{\text{tip}}.$$

2. The heat exit rate from water leaving the volume through the top surface at radius R :

$$-(\dot{V} + \Delta_{\text{melt}}\pi R^2 \nu)\rho_w c_w T_w.$$

If the drill were not advancing (e.g. if the water turned cold and the ice stopped melting), the flow-rate part of this term, in parentheses, would simply be \dot{V} . But, since the ice and the enclosed water are moving upward relative to the control volume, the volume swept by the circle of radius R must be included. The Δ_{melt} factor accounts for the reduction in volume of ice as it melts to water.

3. The rate of heat absorption by warming and melting ice:

$$-\pi R^2 \nu \rho_i (c_f - c_i T_\infty).$$

As the control volume advances downward, ice crosses the bottom of the volume at the far-field temperature at a volume rate of $\pi R^2 \nu$. Since we are using 0°C water as our reference temperature for heat content, this ice is entering with 'negative' heat content. If the heat entering through the hose is greater than this 'negative heat' entering as cold ice, then, when they combine and the ice melts, the resulting water is left with some energy (i.e. a temperature greater than 0°C) that flows up through the top of the control volume (the second term above).

Summing these three terms, setting that sum equal to zero and solving for T_w gives

$$T_w = \frac{1}{\dot{V} + \Delta_{\text{melt}}\pi R^2 \nu} \left[T_{\text{tip}}\dot{V} - \pi R^2 \nu \left(\frac{\rho_i (c_f - c_i T_\infty)}{\rho_w c_w} \right) \right]. \quad (1)$$

Equation (1) gives the temperature of the water as a function of the radius of the hole (R) at points above the drill tip. This shows that (for a given drilling speed, water flow rate, nozzle temperature and far-field ice temperature) the hole radius determines the temperature of the water in the hole. An inverse relation is expected: the bigger the hole, the colder the water.

Solving this for R gives

$$R = \left[\frac{\dot{V}(T_{\text{tip}} - T_w)}{\pi \nu \left(T_w \Delta_{\text{melt}} + \left(\frac{\rho_i (c_f - c_i T_\infty)}{\rho_w c_w} \right) \right)} \right]^{1/2}. \quad (2)$$

The hole will approach its maximum radius up the hole as the temperature of the water approaches 0°C. Setting $T_w = 0$ in Eqn (2) and simplifying gives

$$R_{\text{max}} = \left[\frac{\dot{V} T_{\text{tip}} \rho_w c_w}{\pi \nu \rho_i (c_f - c_i T_\infty)} \right]^{1/2}. \quad (3)$$

Equation (3) shows that (for a given water flow rate, nozzle temperature and far-field ice temperature) the maximum size to which the hole opens is a function of the drill speed. The faster the drill advances, the smaller the maximum hole diameter. This is logical; the faster the drill advances, the less heat is deposited in each meter of depth.

Again, this ignores losses from heat conduction into the ice. For a large hole, it can take up to a few hundred meters for the hole to reach its maximum diameter – in such a case, the assumption of no heat conduction into the ice yields

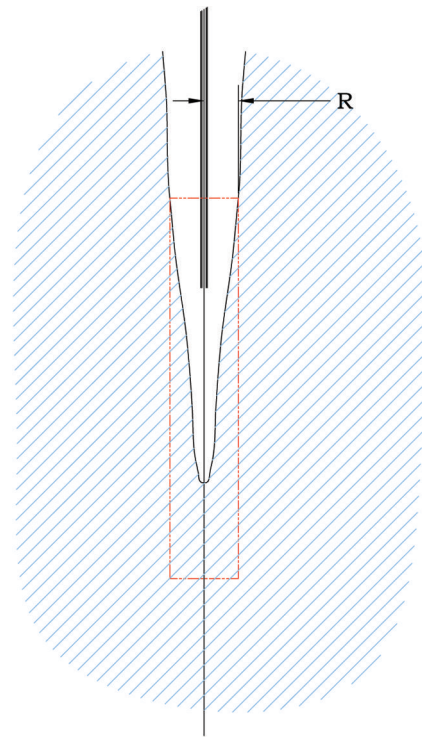

Fig. 1. An idealized drawing of the tip region of the drill during drilling.

inaccurate results. The maximum hole diameter would actually be smaller because of heat lost into the ice.

Note: The assumption that the water temperature is uniform across the hole is an appropriate assumption only if the flow is turbulent rather than laminar. The degree of turbulence is characterized by the Reynolds number ($Re = \dot{V} D_h \rho_w / (A \mu)$, where U is the average water speed, D_h is the hydraulic diameter of the hole, ρ is the water density and μ is the dynamic viscosity of the water). With typical IceCube project parameters, Re is approximately 92 000 at a diameter of 0.15 m and 13 000 at 0.6 m. This is well into the turbulent range; anything above ~ 2000 – 4000 is considered to be turbulent flow in pipes.

Hole shape

The previous calculations give the maximum diameter of the hole but no indication of the time required for the hole to reach that diameter or of how quickly it opens up in the first tens of meters above the tip. The diameter, as a function of distance above the tip, was important for the IceCube project because the hot-water drill had an instrument package housed in a drill body ~ 15 m above the nozzle. The drill speed was limited by the requirement that the hole diameter be greater than the instrument package diameter a minimal distance of 15 m above the nozzle (a slower drill speed gives a larger hole).

Two equations can be written for the rate of heat that goes into ice melting. The first (Eqn (4)) calculates the heat rate required to enlarge a hole by ΔR based on drilling rate and ice temperature. The second (Eqn (5)) expresses the heat transfer rate into the ice as a function of the temperature of the water and the thermal boundary layer at the ice wall.

For the first equation, consider a section of the hole over which the radius increases by ΔR (see Fig. 2). As the ice moves upwards past the drill, at a speed of ν , the rate at

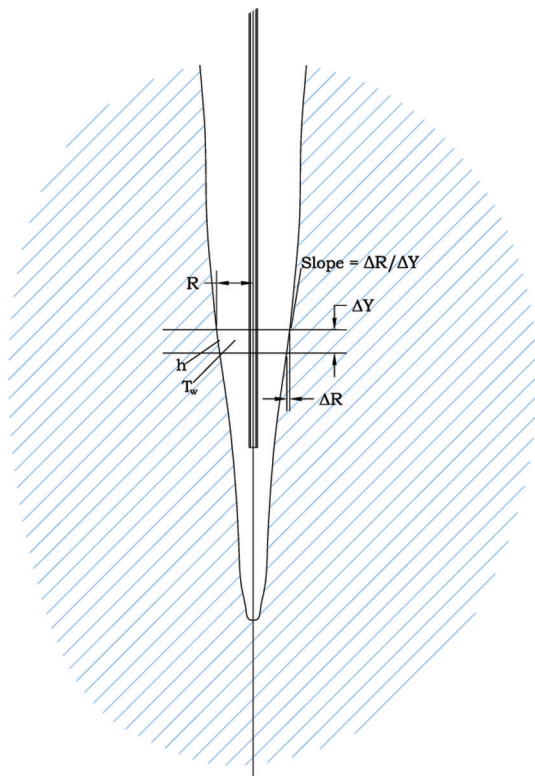

Fig. 2. The basic variables for hole shape equations.

which water heat melts ice in this section is

$$\Delta \dot{Q}_{ice} = (2\pi R \Delta R) v \rho_i (c_f - c_i T_\infty). \tag{4}$$

The second equation is from convective heat transfer at the wall:

$$\frac{\Delta \dot{Q}_{ice}}{\Delta Y} = 2\pi R T_w h. \tag{5}$$

Note that T_w is the temperature difference between the water and wall because the temperature at the wall is 0°C.

Combining Eqns (4) and (5) gives

$$\frac{dY}{dR} = \frac{\rho_i (c_f - c_i T_\infty)}{T_w h}. \tag{6}$$

For flow in a tube, h is given by an empirical equation (Holman, 1976):

$$h = \frac{k}{D_h} 0.023 Re^{0.8} Pr^{0.3}, \tag{7}$$

Table 1. Height in the hole as a function of hole radius

Radius m	Height above nozzle m
0.06*	0.0
0.075	0.4
0.1	2.1
0.15	12.3
0.1572	15.0
0.2	44.7
0.25	154.2
0.3	1700.0
0.301	R_{max}

*The starting condition is $R=0.06$ m at the nozzle tip.

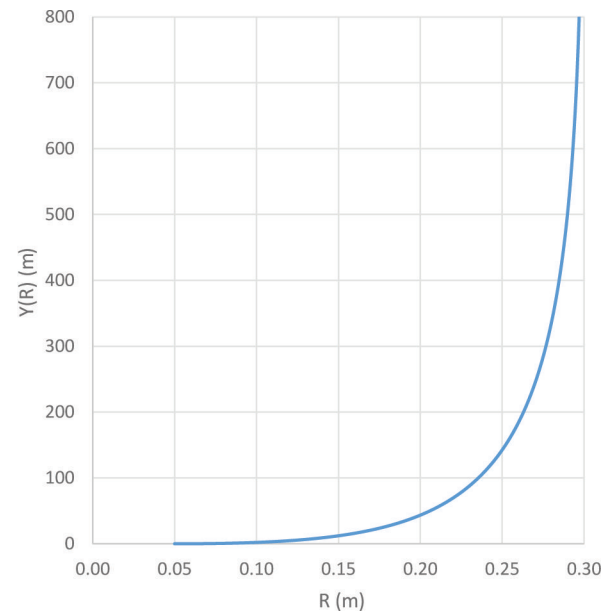

Fig. 3. Height above tip as a function of hole radius.

where k is the thermal conductivity of the fluid, D_h is the hydraulic diameter, Re is the Reynolds number and Pr is the Prandtl number. The parameter k is roughly constant between 0°C and 100°C (with a value of $0.655 \text{ W m}^{-1} \text{ }^\circ\text{C}^{-1}$ at 60°C). For an annulus, D_h is 2 m (outer radius minus inner radius). The viscosity, μ , part of the Reynolds number, and Pr are temperature-dependent. Over the temperature range of interest, they can be approximated by

$$\mu = \frac{1}{27T_w + 500} (\text{kg m}^{-1} \text{ s}^{-1}) \tag{8}$$

and

$$Pr = \frac{1}{0.00493T_w + 0.055} (\text{dimensionless}). \tag{9}$$

Both of these are functions of T_w , and because T_w is known as a function of R , both of these are also functions of R . This means that everything in Eqn (7) can be expressed in terms of R , so that we have h as a function of R . Thus, Eqn (6) takes the form

$$\frac{dY}{dR} = \frac{\rho_i (c_f - c_i T_\infty) v}{T_w(R) h(R)} = F(R) \tag{10}$$

and can be integrated, numerically, to give Y as a function of R (Fig. 3). Note that this plot shows the actual profile of the hole (with the horizontal dimension greatly expanded relative to the vertical dimension).

Table 1 lists some radius and corresponding height values for the following parameters:

- water volume rate: $1.26 \times 10^{-2} \text{ m}^3 \text{ s}^{-1}$ (200 gal min⁻¹)
- water temperature at drill tip: 80°C
- drill advance speed: 2.25 m min⁻¹
- far-field ice temperature: (-50°C, surface ice at South Pole)

The values close to the final hole radius should be regarded with some suspicion since they are in the region where the temperature difference between water and ice has become so small that the hole diameter is growing very slowly. Small changes in hole radius translate to large differences in the Y

Table 2. Water temperature as a function of hole radius (tip temperature 80°C)

Radius m	Temperature °C
0.06*	74.5
0.075	71.5
0.1	65.5
0.15	50.3
0.1572	47.9
0.2	33.1
0.25	16.0
0.3	0.2
0.301	0.0

*The starting condition is $R=0.06$ m at the nozzle tip.

values. Also, in this part of the hole, heat losses into the ice start to become significant, so that the actual radius will be smaller than predicted at a given height.

This analysis ignores the area ahead of the drill tip where the hot water jet is starting to create the hole into the ice. Instead, a hole diameter of 0.06 m is assumed at the tip. The accuracy of this assumption is not critical. An error in the assumed value shifts the calculated hole profile up or down by an amount equal to the distance from the drill tip to the point where the hole is actually 0.06 m. The hole opens up very quickly near the bottom, therefore the upshift or downshift is small (probably <1 m).

If the same R values from above are substituted into Eqn (1), the temperatures (T_w) are as shown in Table 2. At a height of 15 m above the tip (the approximate height of the instrument package), the radius is ~ 0.157 m. The temperature at this height is predicted to be $\sim 48^\circ\text{C}$.

Note that this example calculation uses the ice and water conditions at the South Pole surface. All detailed calculations were actually done using the method described in the next section.

HOLE SHAPE AND DRILLING RATE – INCLUDING HEAT CONDUCTION INTO THE ICE

Including heat conduction losses in these calculations introduces complications. Closed-form calculations are possible for temperature and heat movement in the water-filled hole, given some reasonable approximations and simplifications. The situation is different for the ice surrounding the hole. Heat conduction into the ice, and the resulting temperature distribution, are governed by a partial differential equation. The combination of cylindrical geometry, an infinite solid surrounding the hole (so no steady-state solution) and a moving inner boundary (as ice melts or refreezes) makes solving this differential equation quite difficult.

The approach taken in this investigation was to use explicit equations in the water and a finite-difference approach in the surrounding ice. The two regions are linked by the constant 0°C temperature of the hole wall.

Assumptions

1. The goal in drilling was to produce a hole specified as a certain diameter reached at a certain number of hours

Table 3. Ice temperature with depth at South Pole

Depth m	Temperature °C
250	-50
750	-48
1250	-44
1750	-36
2250	-25

after the end of drilling. Too small a hole would run the risk of not having enough time to complete deployment of the optical modules. Too large a hole would waste expensive energy. The original goal for IceCube was a 45 cm diameter hole 37 hours after drilling was finished, though shorter lifetimes were targeted later.

2. The temperature distribution as a function of depth, at the South Pole, was measured during the Antarctic Muon and Neutrino Detector Array (AMANDA) project (IceCube's predecessor and proof of concept). These temperatures (at a range of depths) are shown in Table 3 and are the basis of a curve-fit equation giving ice temperature as a function of depth.
3. The pump/heater/drill system was designed to deliver $1.26 \times 10^{-2} \text{ m}^3 \text{ s}^{-1}$ (200 gal min^{-1}) of water. The temperature of this water, at the source, was $\sim 88^\circ\text{C}$. The water temperature drops to $\sim 80^\circ\text{C}$ as water travels through the piping on the surface to the top of the hole. It loses additional heat (through the hose into the surrounding water) as it travels through submerged hose. With the hose used in this project (English, inner dimension 2.5 in (6.35 cm), outer dimension 3.75 in (9.53 cm), made of rubber with an average conductivity of $0.26 \text{ W m}^{-1} \text{ }^\circ\text{C}^{-1}$), the water temperature dropped from $\sim 80^\circ\text{C}$ when drilling near the surface to $\sim 66^\circ\text{C}$ when 2500 m below surface.

Working with the steady-state analysis

The heart of this approach is, again, the 'steady-state' control volume as presented in the previous section. In this steady state, one can calculate the rate at which heat flows from the water into the water-ice interface and the rate at which it flows from the interface into the colder ice.

- a. From the heat flow rate out of the water, the rate of change of water temperature can be found.
- b. The radial temperature profile in the ice determines the heat flow rate into the ice. From the heat flow into the ice, the rate of change of the temperature profile can be calculated.
- c. The difference between the heat-flow rates into and out of the interface gives the rate of ice melting or ice forming at the interface. This gives the time rate of change of the hole radius.

Some of these derivatives are initially found with respect to Y , the height above the drill tip. These can be converted to derivatives with respect to time since ΔY and Δt are related by $\Delta Y/\Delta t = v$, the drill advance speed. (The changes in T_w and R at a distance ΔY higher in the hole in the drill-tip fixed

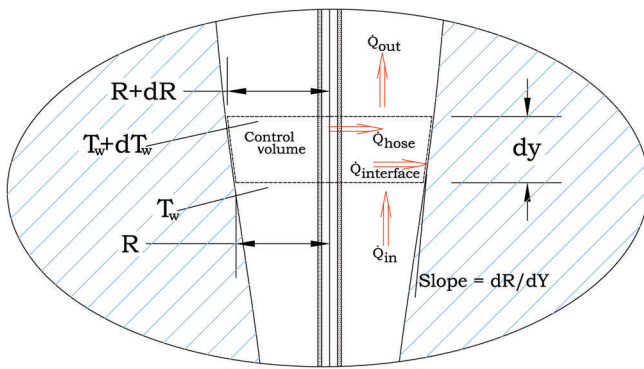

Fig. 4. The control volume used to derive the dT/dt equation.

coordinate system are the same as the values that would be seen at a fixed depth in the ice at a time Δt later.) In this way the calculation is turned into a calculation of the evolution of the hole at a fixed depth in the ice.

This process can be applied throughout the drilling, reaming and freezeback phases of the hole. Since the temperature of the ice is not actually constant with changing depth, the total depth can be divided into sections and the above calculation performed at the center of each section. The results from each of the sections can then be placed together to give a time history of the hole, and the ice surrounding the hole, out to a radius that is close to the far-field temperature.

In the case of the IceCube project, the hole was usually treated as 25 sections, each 100 m deep. The ice temperature variation within one section did not affect the calculation results significantly.

The water

Consider some height above the tip where the radius of the hole is R and the bulk temperature of the water is T_w (Fig. 4). The velocity of the water up the hole gives the Reynolds number of the flow and, in turn, the convective heat transfer coefficient, h , from Eqn (7). (Equation (7) is intended specifically for this situation with the bulk temperature of a fluid in tube flow.)

The interface, the actual wall of the hole, stays at 0°C (our reference temperature for heat content). The heat rate into this interface, per meter of hole depth, is

$$\dot{Q} = 2\pi R h T_w. \quad (11)$$

This heat into the interface can be thought of as being split into two destinations: some of it is conducted into the ice at a rate determined by the thermal conductivity of the ice and the temperature gradient in its surface; the rest melts ice and enlarges the hole. This heat rate that goes into melting determines how fast the radius of the hole is increasing, and is given by

$$\frac{dR}{dt} = \frac{\dot{Q}_{\text{melting}}}{2\pi R \rho_i c_f}, \quad (12)$$

where \dot{Q}_{melting} is the rate (W m^{-1} of hole depth) at which heat goes into melting ice. Note that at some stages of the drilling process the heat drawn off by the temperature gradient in the ice is larger than that being transmitted into the interface from the water. Then \dot{Q}_{melting} is negative, and, instead of melting, we get refreezing of the hole.

The individual terms of an energy balance for a small dY of the hole are:

1. the heat flow in, by water (the volume flow rate of water into the control volume multiplied by its density, specific heat and temperature):

$$\dot{Q}_{\text{in}} = [\dot{V} + \Delta_{\text{melt}} v \pi R^2] \rho_w c_w T_w, \quad (13)$$

2. the heat flow out, by water (the volume flow rate of water out of the control volume multiplied by its density, specific heat and temperature):

$$\dot{Q}_{\text{out}} = [\dot{V} + \Delta_{\text{melt}} v \pi (R + dR)^2] \rho_w c_w (T_w + dT_w), \quad (14)$$

3. the heat rate, per meter of hose, conducted in from the warm hose:

$$\dot{Q}_{\text{from hose}} = \dot{Q}_{\text{hose}} dY, \quad (15)$$

4. the heat rate into the interface, as described above:

$$\dot{Q}_{\text{interface}} = 2\pi R h T_w dY. \quad (16)$$

These terms are summed and set equal to zero. Simplifying and rearranging gives an expression for dT_w/dY . However, the hole conditions at a distance ΔY above the depth of interest in our hole are identical to the conditions at the depth an appropriate Δt later. So, without violating the steady-state assumptions we can find the evolution of the hole at a fixed depth with the substitutions

$$\frac{dT_w}{dY} = \frac{1}{v} \frac{dT_w}{dt} \quad (17)$$

and

$$\frac{dR}{dY} = \frac{1}{v} \frac{dR}{dt}. \quad (18)$$

This gives

$$\frac{dT_w}{dt} = \frac{\dot{Q}_{\text{hose}} - 2\pi R T_w [h + \Delta_{\text{melt}} \rho_w c_w dR/dt]}{[\dot{V} + \Delta_{\text{melt}} v \pi R^2] (\rho_w c_w / v)}. \quad (19)$$

An initial hole radius, R_0 , is assumed, and the corresponding initial water temperature, T_{w0} , is calculated from Eqn (1). Note that T_{w0} will be less than T_{tip} as heat has already been expended to open the hole to R_0 . The rate of change of the hole size and of the hole water temperature are calculated from Eqns (12) and (19), and then the new radius and temperature found for a small subsequent Δt . This process is iterated to predict the development of the hole.

The accuracy of the value that is assumed for the initial hole radius (at tip level) is not very important. As before, an error here only shifts the vertical position of the entire hole up or down relative to the drill. The hole radius is changing very fast in this region so the shift will be small.

The ice

As mentioned above, the heat that goes into melting ice at the hole wall is the difference between the heat that goes into that interface (Eqn 11) and the heat that is conducted into the ice. The heat conducted into the ice depends on the thermal conductivity, k , of the ice and the temperature gradient in the ice immediately adjacent to the wall. To determine this temperature gradient, the temperature profile in the ice is calculated and stepped forward along with the water temperature and the hole radius. The initial temperature profile is assumed to be 0°C at the hole surface (R_{initial}) and T_∞ everywhere else.

The governing equation for the change of temperature in the ice is

$$\frac{\partial^2 T}{\partial r^2} + \frac{1}{r} \frac{\partial T}{\partial r} = \frac{1}{\alpha} \frac{\partial T}{\partial t}. \quad (20)$$

This equation was solved in MATLAB[®] with a standard finite-difference method based on the temperature along a row of points extending outward from the hole wall. This temperature profile is integrated forward each Δt using a modified Euler method of integration that is second-order accurate (the standard Euler method is first-order accurate).

At each time step, the change in radius is calculated from the amount of heat that goes into melting. After this new hole radius is found, the grid is shifted so that the innermost point of the grid stays at the hole wall. The temperature of the point at the wall is set to zero and the temperatures of the remaining points are interpolated from the temperatures of the unshifted grid.

If the temperature profile is known, then so is the temperature gradient (dT/dr) in the ice at the hole wall. This gives the rate of heat conduction into the ice. As the ice at the hole wall melts, the 0°C hole wall is pushed out into the colder ice, creating steep temperature gradients. (Physically, these steep temperature gradients are necessary to get the heat into the <0°C ice to warm it to 0°C before melting. The faster the melting boundary advances, in cold ice, the steeper these gradients need to be to get enough heat into the ice.) Steep temperature gradients such as these are sensitive to numerical error and so require a fine mesh for accurate values at the advancing wall. Since the numerical value of the gradient at the wall is a very important number, it is crucial to use an adequately fine grid and time step. In this case, adequate fineness was determined by refining the grid and time step until the results showed little change with further refinement. In the parts of drilling where the hole size is changing slowly or when the hole is refreezing, this situation does not exist, and a coarser physical grid and time step may be used.

Reaming

The method just discussed works well for the downward phase of drilling. However, a modified approach is needed when modeling the ream phase of the operation. During reaming, the drill travels up, leaving hot water in the hole. Since the water in the hole is not moving after the drill passes by, heat transfer is driven by conduction and natural convection, making it impossible to calculate the heat transfer into the ice in the same way as was done during drilling. Fortunately, we are not as concerned with the evolution of the hole shape during the ream; we just want to know the ultimate increase in radius due to the ream.

The method used relies on the fact that, if you know the rate at which the nozzle is delivering heat and the rate at which the drill is being raised, you know the amount of heat delivered per meter of hole during the ream. The heat delivered ($J m^{-1}$) is a simple function of the drill speed and the water flow rate and temperature.

The approach taken was to assume that the heat went from the water into the interface during a fixed interval of time after the upward passing of the drill nozzle. The heat delivered to the wall was then divided as before, where some was conducted away into the ice (based on dT/dr) and the difference was used to calculate melting or refreezing. To make the calculation more realistic, the heat deposited by the drill during reaming is delivered to the wall in a

decreasing exponential fashion. This is similar to assuming a fixed heat-transfer coefficient.

The time over which it is assumed that the heat transfers into the wall is an estimate. However, trials showed that the final hole size and freezeback rate were very insensitive to this estimated length of time.

Freezeback

Freezeback is not a distinct mode in these calculations. If the heat being conducted from the water into the water–ice interface is greater than the heat being drawn off by the ice, melting occurs and the hole grows. If heat is being drawn from the water–ice interface faster than it is being replaced by heat from the water, then freezing occurs. The hole can transition from growing to freezing without a change in method of calculation.

RESULTS

Drill speed and elapsed time

Since the drill equations are derived assuming constant properties, the hole is divided, depth-wise, into sections small enough that the depth-linked variables (ice temperature and drill-tip water temperature) can be taken to be approximately constant over those sections. The values used are those calculated at the depth of the middle of the section. The described method is then used to analyze the development of the hole at the middle of each of these sections.

Drill-tip temperature is approximately a decaying exponential with depth since most of the surrounding water is at 0°C and heat loss from the water in the hose at any point is proportional to its temperature.

To determine the time between drilling and reaming for a section (this dwell time affects the reaming), the drill and ream speeds used in the sections below this point are needed. Therefore, the calculation starts with the lowest section, and the drill and ream speeds that gave a hole of the desired diameter in that section are found. Then the second lowest section can be analyzed since the time taken to travel down and back up through the lowest section is known. This process is repeated, moving higher one section at a time, until the top of the hole is reached and all sections have been analyzed.

There is a trade-off between drilling and reaming; slower drilling (bigger hole during drilling) means less reaming needed and vice versa. It was found convenient to pick ream speeds in advance and then adjust the drill speed in each section to yield the target diameter within the target time. This makes it possible to calculate when drilling and reaming will be finished, which allows for determining the lifetime of each section of hole after that point.

A typical plot compiled from the raw model output data is shown in Figure 5. Each trace shows the evolution of the hole over time at a different depth. (The trace at 1650 m is darkened in this plot as an example.) The example trace shows that the drill reaches 1650 m about 15 hours into the drilling operation and that the hole initially opens up quite quickly. It stops expanding and starts to freeze back while the drill tip is lower; then, during reaming, it opens up further. After reaming, it reaches its maximum size and then starts its final freezeback. The freezeback rate can be seen to be faster in the shallow (colder) ice than in the deep (warmer) ice. In this example a constant 4.5 m min^{-1} ream speed was used at all depths but the drill speeds were varied

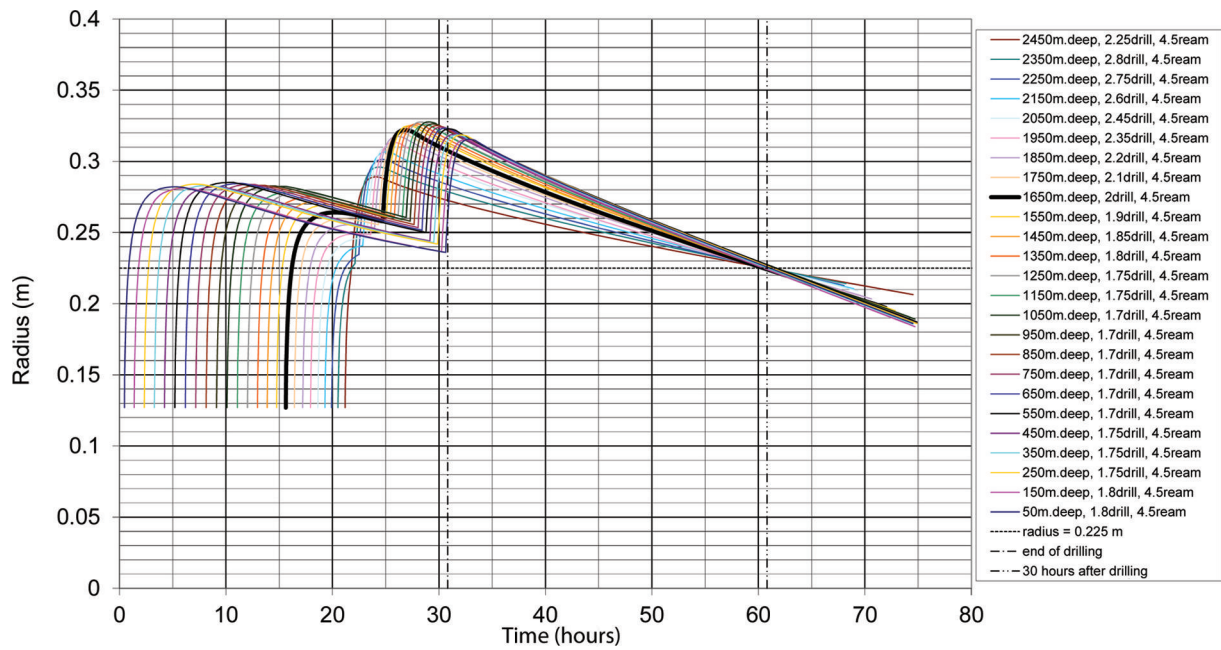

Fig. 5. Typical output from the model for a hole with a 30 hour lifetime (drill and ream speeds in m min^{-1}). Radius vs time at a range of depths (with time increments of 1 hour).

in each section to give a lifetime, everywhere in the hole, of 30 hours (i.e. all sections of the hole froze back to 45 cm diameter 30 hours after the end of reaming).

Once this process is finished and the drill and ream speeds are found for each section, the total elapsed time for the entire process of drilling and reaming a hole may be found by summing the times for each section.

Energy consumption

The heat rate flowing down the hose comes from the product of volume flow rate of water down through the hose, density and specific heat, which is then multiplied by the difference between the supply and return temperatures of the water. This heat rate multiplied by the total elapsed drilling and reaming time gives the total amount of heat

pumped down the hole. If an estimate can be made of the amount of fuel required to produce this amount of heat (given the characteristics of the heating plant), one can calculate the fuel consumption for a hole.

Comparisons between predictions and logged holes

A few holes were measured ('logged') for comparison with the model predictions. Figure 6 shows the measured vs the calculated diameter of one of these logged holes. The two lines labeled A show the measured and calculated diameter during drilling. The smooth line is the predicted diameter–depth profile and the jagged line is the measured profile (measured with instrumentation on the drill body). The drill body was 23 m above the tip, and the plot is calculated for that location. The lines loop because they show the diameter

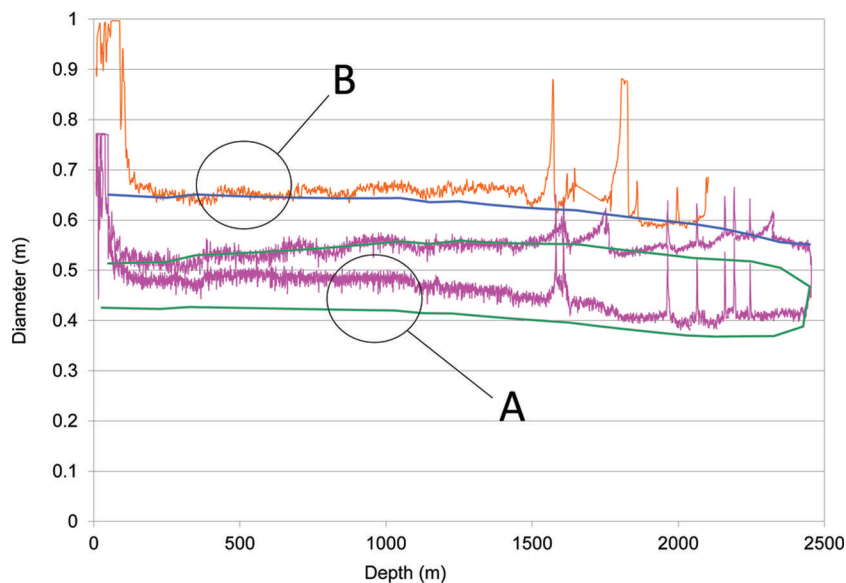

Fig. 6. A comparison of predicted (smooth line) and measured (jagged line) hole sizes (diameter vs depth in hole 40): (A) during drilling; (B) 4 hours after drilling was completed.

during drilling down and during reaming back up. On the way down, the sensor follows the drill tip by roughly 10 minutes. On the way up, the sensor is leading and therefore measures the hole diameter just before reaming. It is apparent from the plot that the model underestimates the diameter by a few centimeters on the way down, just as the hole is opening, but is very accurate on the way up, just before reaming. The B lines show the result of a bottom-up measurement 4 h after drilling was completed. The logger used for this was a custom device made for this purpose by the Welsh company Robertson Geologging.

At this time, the prediction was, again, fairly accurate. Where the prediction deviated from the measurements, it underestimated the hole size.

In general, the model seems to be accurate or slightly conservative (predicting a smaller hole than measured) everywhere except that it is overly conservative in the first tens of meters directly above the drill tip. The evidence to date suggests that the hole opens up faster than predicted in these first tens of meters, but above that there is good agreement between prediction and measurement throughout reaming and freezeback. Increasing the accuracy of this lower section would be a goal for future work.

CONCLUSIONS

Based on first principles instead of on empirical observations and curve fits, we developed a model for predicting hole sizes and hole lifetimes in hot-water drilling. The model was successful as applied to hot-water borehole drilling in

Antarctica for the IceCube project. Indeed, based on the model predictions, the planned lifetime of the hole (from end of drilling through freezeback to 45 cm) was decreased from 37 h on the early holes to ~30 or 24 h on the later holes. This resulted in significant fuel savings for the project.

We hope to use the model in other ice-drilling projects to test outcomes with other parameter sets and to gain increased confidence in the general applicability of this method.

ACKNOWLEDGEMENTS

We thank the National Science Foundation for their generous support through grant NSF OPP-0236449, and are grateful to the US National Science Foundation Office of Polar Programs and the US National Science Foundation – Physics Division. We also thank the University of Wisconsin Alumni Research Foundation. We are grateful to Raytheon Polar Services Corporation for logistics and field support, and also to all of the drillers who helped make IceCube construction a success.

REFERENCES

- Benson T and 9 others (2014) IceCube-enhanced hot water drill functional description. *Ann. Glaciol.*, **55**(68) (doi: 10.3189/2014AoG68A032) (see paper in this issue)
- Holman JP (1976) *Heat transfer*, 4th edn. McGraw-Hill, New York
- Humphrey N and Echelmeyer K (1990) Hot-water drilling and borehole closure in cold ice. *J. Glaciol.*, **36**(124), 287–298 (doi: 10.3189/002214390793701354)